

BC817... TRANSISTOR (NPN)

FEATURE

- For general AF applications
- High collector current
- High current gain
- Low collector-emitter saturation voltage
- Complementary types: BC807 (PNP)

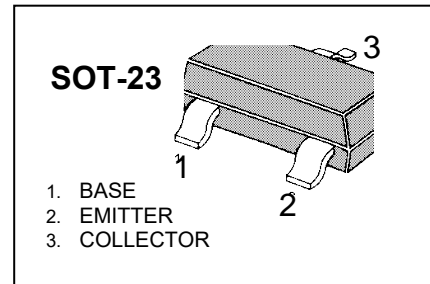

MAXIMUM RATINGS ($T_A=25^{\circ}\text{C}$ unless otherwise noted)

Symbol	Parameter	Value	Units
V_{CB0}	Collector-Base Voltage	50	V
V_{CE0}	Collector-Emitter Voltage	45	V
V_{EB0}	Emitter-Base Voltage	5	V
I_C	Collector Current -Continuous	0.5	A
P_C	Collector Power Dissipation	0.3	W
T_j	Junction Temperature	150	$^{\circ}\text{C}$
T_{stg}	Storage Temperature	-55-150	$^{\circ}\text{C}$

ELECTRICAL CHARACTERISTICS ($T_{amb}=25^{\circ}\text{C}$ unless otherwise specified)

Parameter	Symbol	Test conditions	MIN	TYP	MAX	UNIT
Collector-base breakdown voltage	V_{CB0}	$I_C = 10\mu\text{A}$, $I_E = 0$	50			V
Collector-emitter breakdown voltage	V_{CE0}	$I_C = 10\text{mA}$, $I_B = 0$	45			V
Emitter-base breakdown voltage	V_{EB0}	$I_E = 1\mu\text{A}$, $I_C = 0$	5			V
Collector cut-off current	I_{CB0}	$V_{CB} = 45\text{V}$, $I_E = 0$			0.1	μA
Emitter cut-off current	I_{EB0}	$V_{EB} = 4\text{V}$, $I_C = 0$			0.1	μA
DC current gain	$h_{FE(1)}$	$V_{CE} = 1\text{V}$, $I_C = 100\text{mA}$	100		600	
	$h_{FE(2)}$	$V_{CE} = 1\text{V}$, $I_C = 500\text{mA}$	40			
Collector-emitter saturation voltage	$V_{CE(sat)}$	$I_C = 500\text{mA}$, $I_B = 50\text{mA}$			0.7	V
Base-emitter saturation voltage	$V_{BE(sat)}$	$I_C = 500\text{mA}$, $I_B = 50\text{mA}$			1.2	V
Base-emitter voltage	V_{BE}	$V_{CE} = 1\text{V}$, $I_C = 500\text{mA}$			1.2	V
Collector capacitance	C_{ob}	$V_{CB} = 10\text{V}$, $f = 1\text{MHz}$		10		pF
Transition frequency	f_T	$V_{CE} = 5\text{V}$, $I_C = 10\text{mA}$ $f = 100\text{MHz}$	100			MHz

CLASSIFICATION OF $h_{FE(1)}$

Rank	BC817-16	BC817-25	BC817-40
Range	100-250	160-400	250-600
Marking	6A	6B	6C

Typical Characteristics

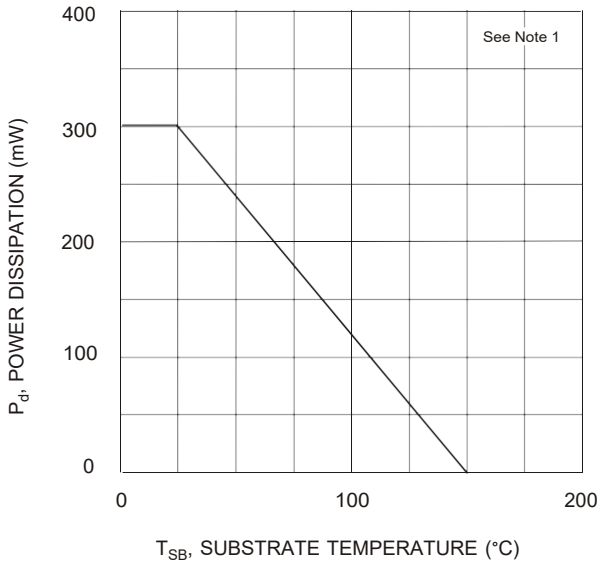

Fig. 1, Power Derating Curve

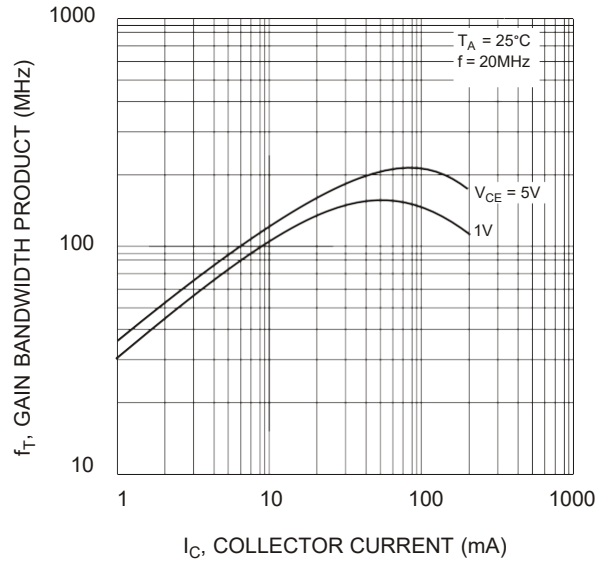

Fig. 2, Gain-Bandwidth Product vs Collector Current

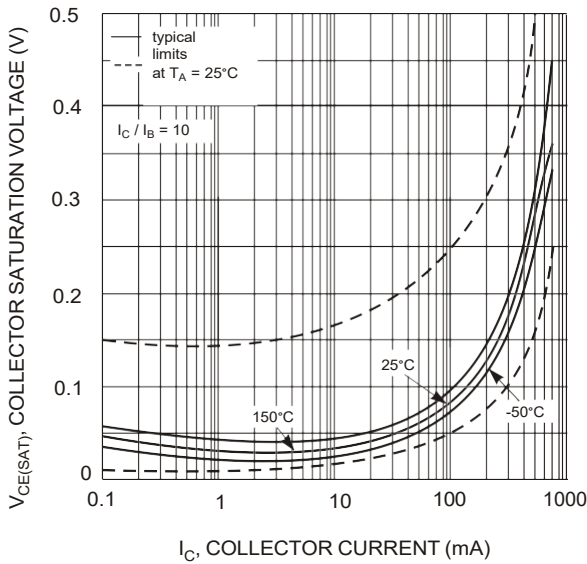

Fig. 3, Collector Sat. Voltage vs Collector Current

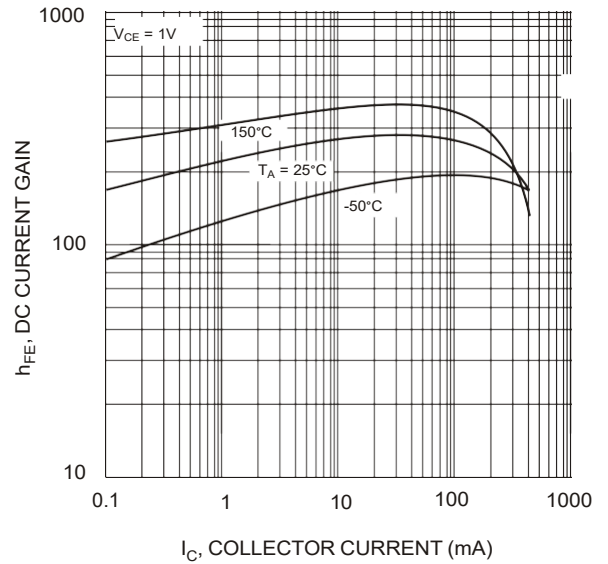

Fig. 4, DC Current Gain vs Collector Current

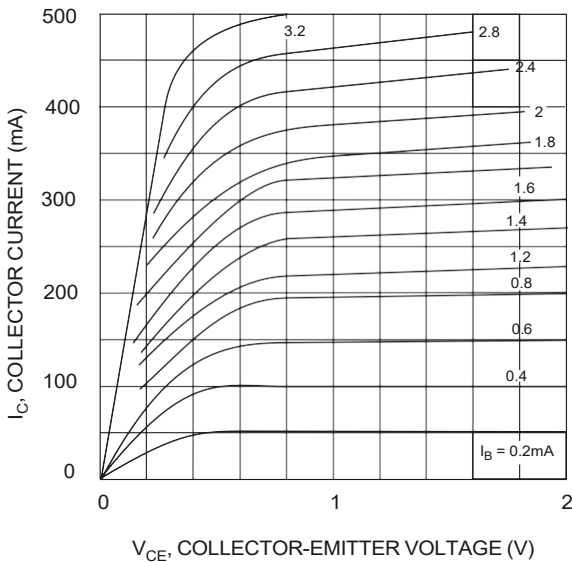

Fig. 5, Typical Emitter-Collector Characteristics

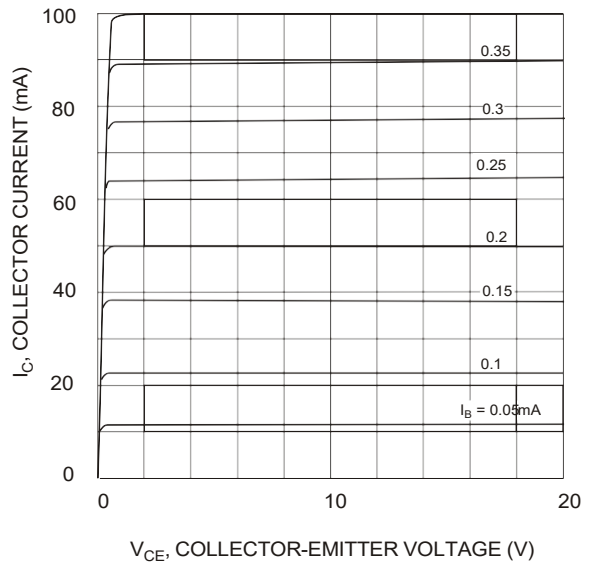
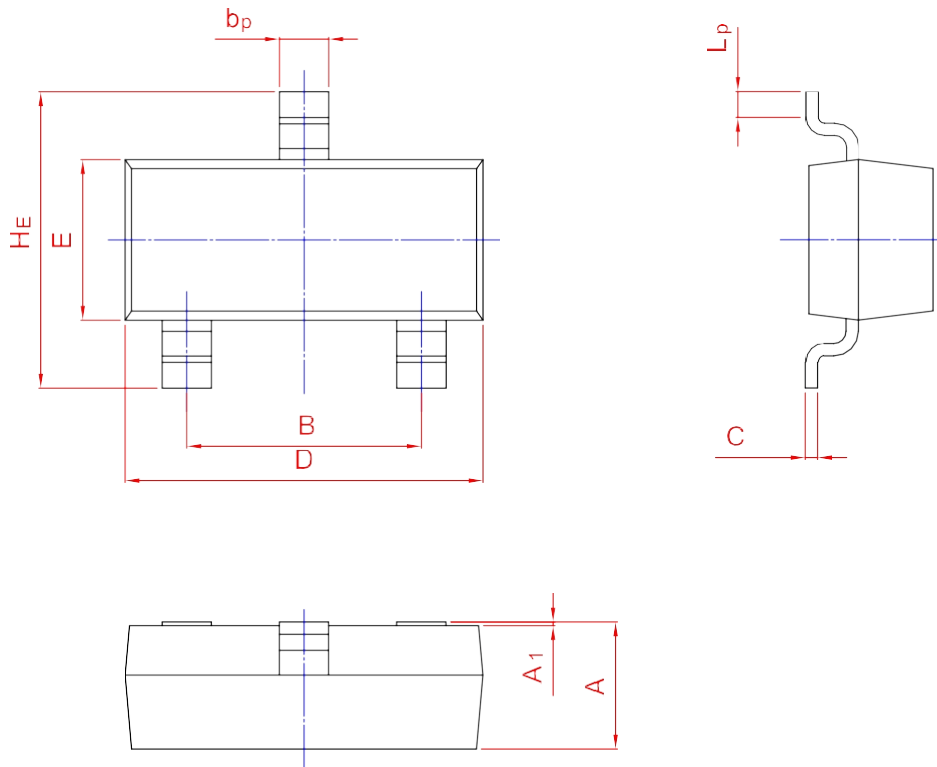

Fig. 6, Typical Emitter-Collector Characteristics

PACKAGE OUTLINE

Plastic surface mounted package; 3 leads

SOT-23



UNIT	A	B	b_p	C	D	E	H_E	A_1	L_p
mm	1.40	2.04	0.50	0.19	3.10	1.65	3.00	0.100	0.50
	0.95	1.78	0.35	0.08	2.70	1.20	2.20	0.013	0.20