

SOD-123 Plastic-Encapsulate Diodes

B0520LW SCHOTTKY BARRIER DIODE

Features

- Low Forward Voltage Drop
- Guard Ring Construction for Transient Protection
- High Conductance
- Also Available in Lead Free Version

PINNING

PIN	DESCRIPTION
1	Cathode
2	Anode

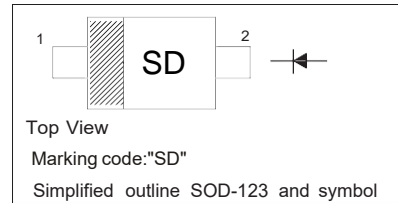

Maximum Ratings @ $T_A = 25^\circ\text{C}$ unless otherwise specified

Single phase, half wave, 60Hz, resistive or inductive load.
For capacitive load, derate current by 20%.

Characteristic	Symbol	B0520LW	Unit
Peak Repetitive Reverse Voltage Working Peak Reverse Voltage DC Blocking Voltage	V_{RRM} V_{RWM} V_R	20	V
RMS Reverse Voltage	$V_{R(RMS)}$	14	V
Average Rectified Output Current @ $T_L = 90^\circ\text{C}$	I_o	0.5	A
Non-Repetitive Peak Forward Surge Current 8.3ms single half sine-wave superimposed on rated load (JEDEC Method)	I_{FSM}	5.5	A
Power Dissipation (Note 1)	P_d	500	mW
Typical Thermal Resistance Junction to Ambient (Note 1)	R_{SJA}	244	$^\circ\text{C}/\text{W}$
Operating and Storage Temperature Range	T_j, T_{STG}	-65 to +125	$^\circ\text{C}$
Voltage Rate of Change	dv/dt	1000	$\text{V}/\mu\text{s}$

Electrical Characteristics @ $T_A = 25^\circ\text{C}$ unless otherwise specified

Characteristic	Symbol	B0520LW	Unit	Test Conditions
Minimum Reverse Breakdown Voltage (Note 2)	$V_{(BR)R}$	20	V	$I_R = 250\mu\text{A}$
Maximum Forward Voltage Drop (Note 2)	V_{FM}	0.300 0.385 0.220 0.330	V	$I_F = 0.1\text{A}, T_j = 25^\circ\text{C}$ $I_F = 0.5\text{A}, T_j = 25^\circ\text{C}$ $I_F = 0.1\text{A}, T_j = 100^\circ\text{C}$ $I_F = 0.5\text{A}, T_j = 100^\circ\text{C}$
Maximum Leakage Current (Note 2)	I_{RM}		μA	$V_R = 10\text{V}, T_j = 25^\circ\text{C}$ $V_R = 20\text{V}, T_j = 25^\circ\text{C}$
		5.0 8.0	mA	$V_R = 10\text{V}, T_j = 100^\circ\text{C}$ $V_R = 20\text{V}, T_j = 100^\circ\text{C}$
Total Capacitance	C_T	170	pF	$f = 1\text{MHz}, V_R = 0\text{V DC}$

- Notes:
1. Device mounted on FR-4 PC board, 2"x2", 2 oz. Copper, single sided, Cathode pad dimensions 0.75"x1.0", Anode pad dimensions 0.25"x1.0".
 2. Pulse Test: Pulse width = 300 μs , Duty Cycle $\leq 2\%$.
 3. dv/dt measured at rated V_R .

Typical Characteristics

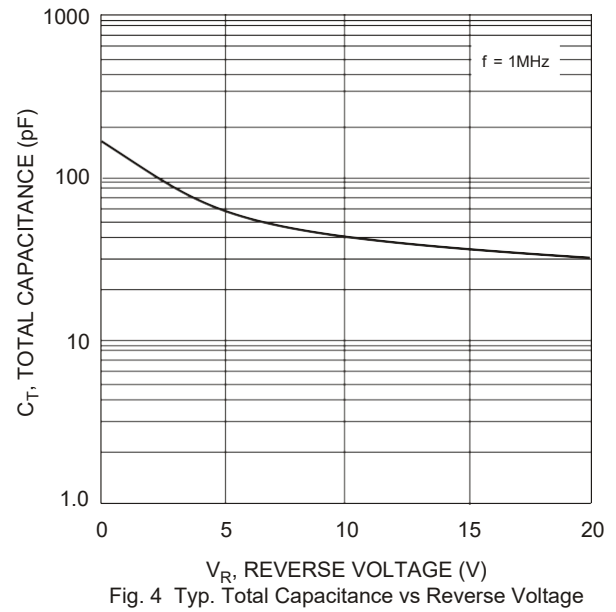
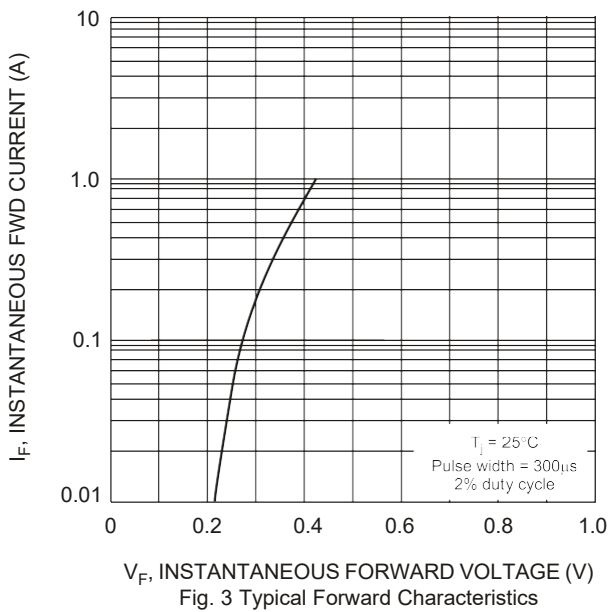
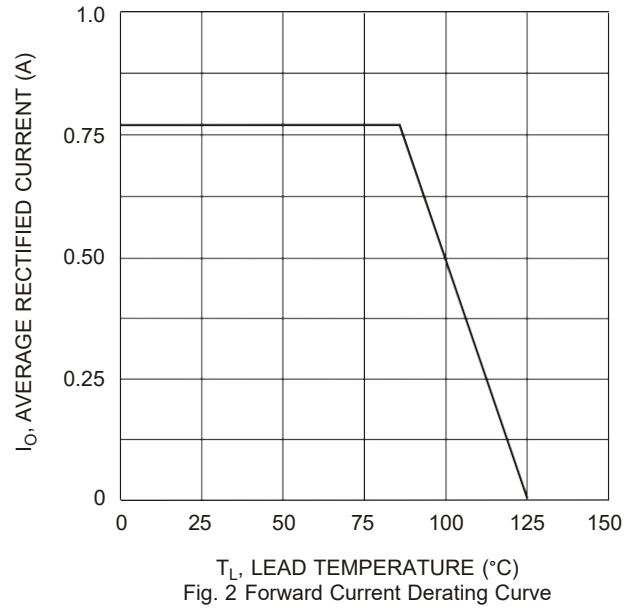
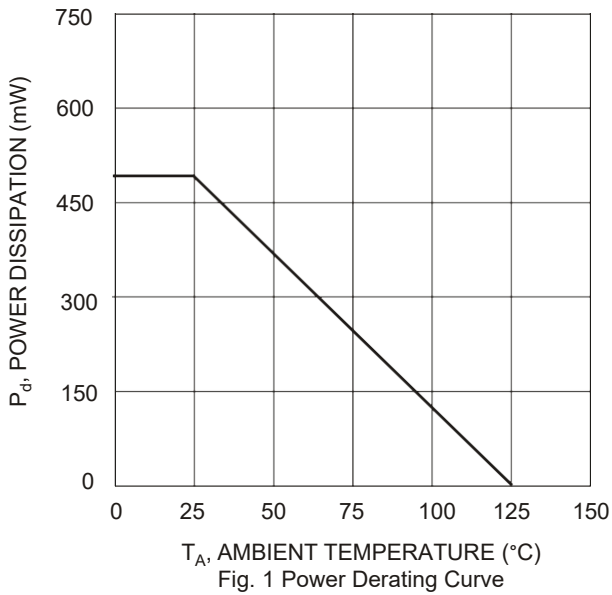

PACKAGE OUTLINE

Plastic surface mounted package; 2 leads

SOD-123

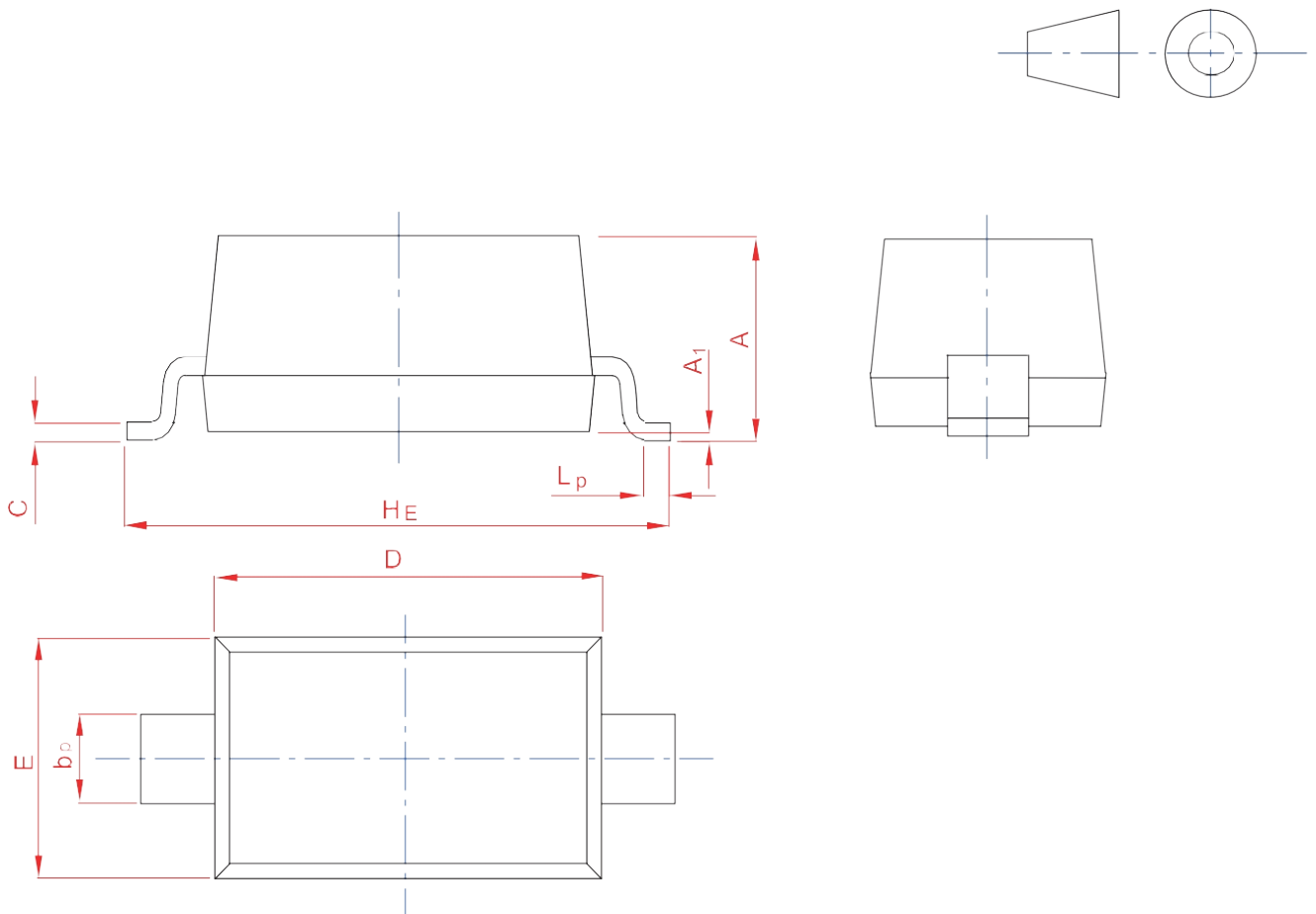

UNIT	A	bp	C	D	E	HE	A1	Lp
mm	1.20	0.60	0.135	2.75	1.65	3.85	0.10	0.50
	0.90	0.50	0.100	2.55	1.55	3.55	0.01	0.20