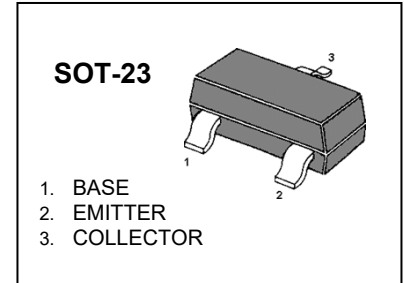

MMBT5551 TRANSISTOR (NPN)**FEATURES**

Complementary to MMBT5401

Ideal for medium power amplification and switching

MARKING: G1**MAXIMUM RATINGS (T_A=25°C unless otherwise noted)**

Symbol	Parameter	Value	Units
V _{CBO}	Collector-Base Voltage	180	V
V _{CEO}	Collector-Emitter Voltage	160	V
V _{EBO}	Emitter-Base Voltage	6	V
I _C	Collector Current -Continuous	0.6	A
P _C	Collector Power Dissipation	300	mW
T _j	Junction Temperature	150	°C
T _{stg}	Storage Temperature	-55-150	°C

ELECTRICAL CHARACTERISTICS (T_{amb}=25°C unless otherwise specified)

Parameter	Symbol	Test conditions	MIN	TYP	MAX	UNIT
Collector-base breakdown voltage	V _{(BR)CBO}	I _C =100μA, I _E =0	180			V
Collector-emitter breakdown voltage	V _{(BR)CEO} *	I _C =1mA, I _B =0	160			V
Emitter-base breakdown voltage	V _{(BR)EBO}	I _E =10μA, I _C =0	6			V
Collector cut-off current	I _{CBO}	V _{CB} =120V, I _E =0			50	nA
Emitter cut-off current	I _{EBO}	V _{EB} =4V, I _C =0			50	nA
DC current gain	h _{FE1} *	V _{CE} =5V, I _C =1mA	80			
	h _{FE2} *	V _{CE} =5V, I _C =10mA	100		300	
	h _{FE3} *	V _{CE} =5V, I _C =50mA	50			
Collector-emitter saturation voltage	V _{CEsat} *	I _C =10mA, I _B =1mA			0.15	V
		I _C =50mA, I _B =5mA			0.2	
Base-emitter saturation voltage	V _{BEsat} *	I _C =10mA, I _B =1mA			1	V
		I _C =50mA, I _B =5mA			1	
Transition frequency	f _T	V _{CE} =10V, I _C =10mA, f=100MHz	100		300	MHz
Collector output capacitance	C _{ob}	V _{CB} =10V, I _E =0, f=1MHz			6	pF
Input capacitance	C _{ib}	V _{BE} =0.5V, I _C =0, f=1MHz			20	pF
Noise figure	NF	V _{CE} =5V, I _C =0.25mA, f=10Hz to 15.7KHz, R _s =1kΩ			8	dB

Typical Characteristics

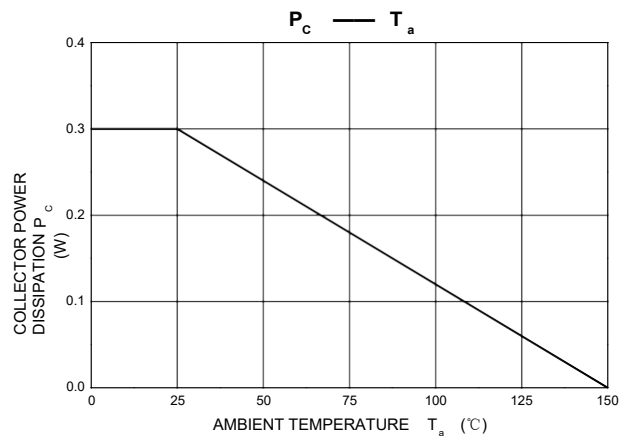
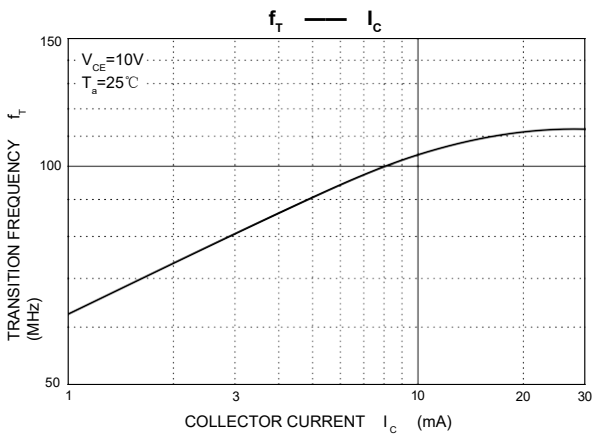
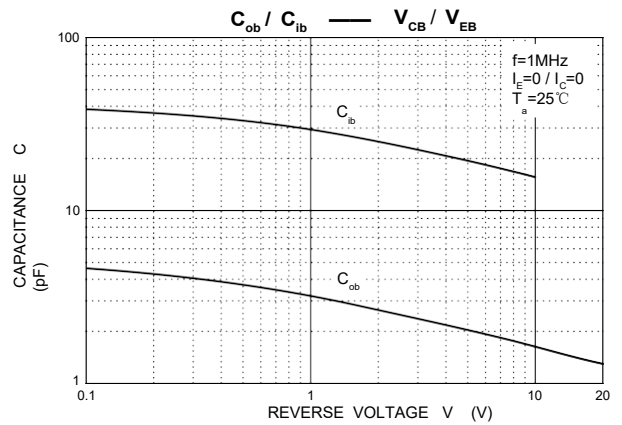
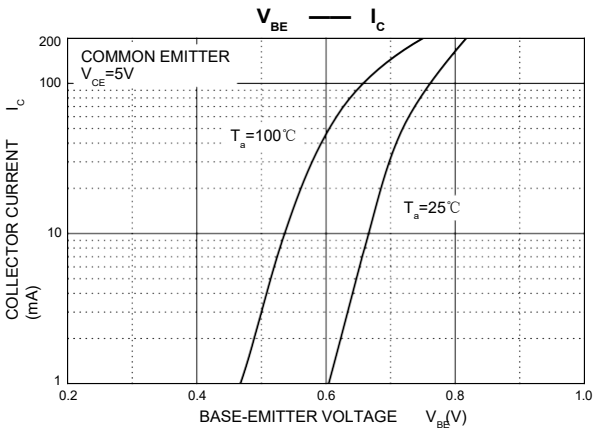
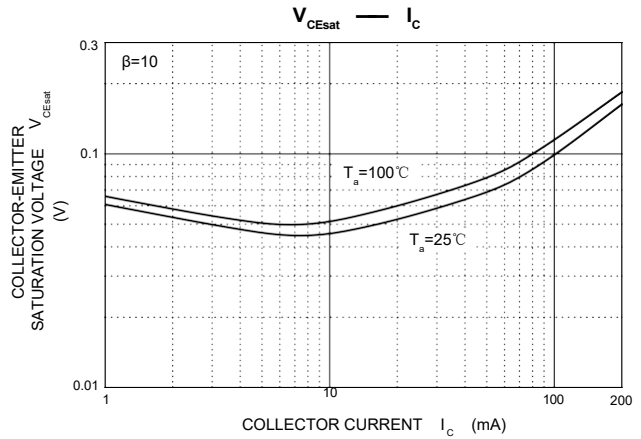
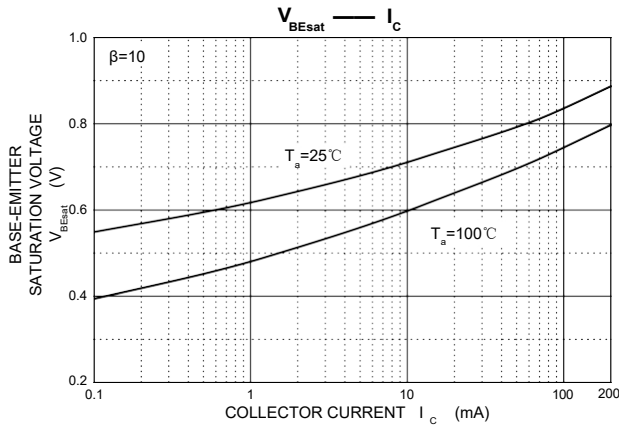
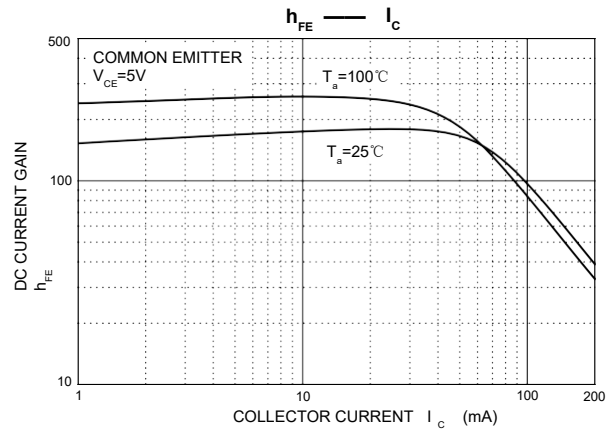
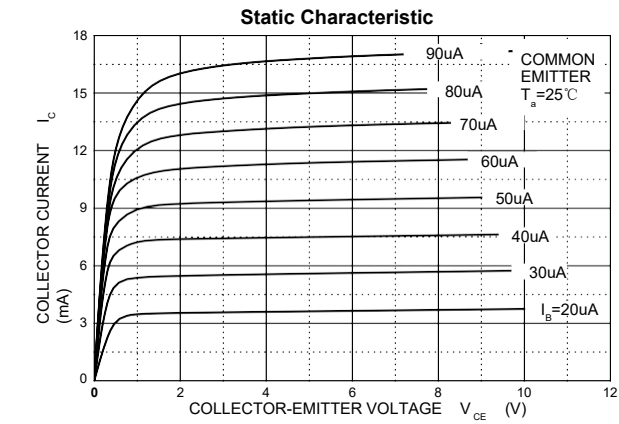

PACKAGE OUTLINE

Plastic surface mounted package; 3 leads

SOT-23

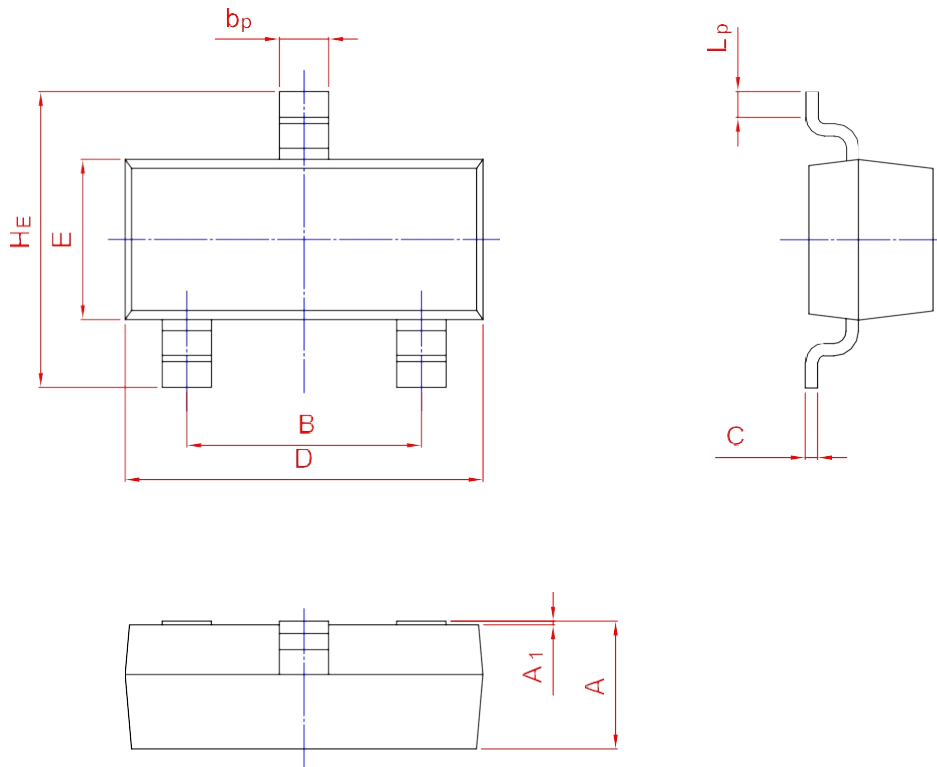
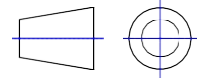

UNIT	A	B	b _p	C	D	E	H _E	A ₁	L _p
mm	1.40	2.04	0.50	0.19	3.10	1.65	3.00	0.100	0.50
	0.95	1.78	0.35	0.08	2.70	1.20	2.20	0.013	0.20