

## S9018 TRANSISTOR (NPN)

### FEATURES

AM/FM Amplifier, Local Oscillator of FM/VHF Tuner  
 High Current Gain Bandwidth Product  $f_T=1.1$  GHz (Typ)

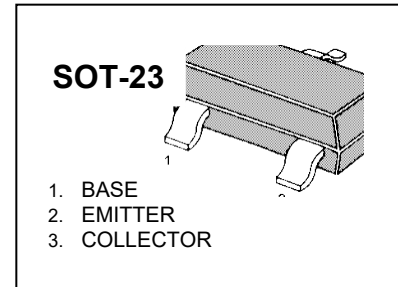

**MARKING : J8**

### MAXIMUM RATINGS ( $T_A=25^\circ\text{C}$ unless otherwise noted)

Symbol	Parameter	Value	Units
$V_{CBO}$	Collector-Base Voltage	30	V
$V_{CEO}$	Collector-Emitter Voltage	15	V
$V_{EBO}$	Emitter-Base Voltage	5	V
$I_C$	Collector Current -Continuous	50	mA
$P_C$	Collector Power Dissipation	200	mW
$T_j$	Junction Temperature	150	$^\circ\text{C}$
$T_{stg}$	Storage Temperature	-55-150	$^\circ\text{C}$

### ELECTRICAL CHARACTERISTICS ( $T_{amb}=25^\circ\text{C}$ unless otherwise specified)

Parameter	Symbol	Test conditions	MIN	TYP	MAX	UNIT
Collector-base breakdown voltage	$V_{(BR)CBO}$	$I_C=100\mu\text{A}$ , $I_E=0$	30			V
Collector-emitter breakdown voltage	$V_{(BR)CEO}$	$I_C=1\text{mA}$ , $I_B=0$	15			V
Emitter-base breakdown voltage	$V_{(BR)EBO}$	$I_E=100\mu\text{A}$ , $I_C=0$	5			V
Collector cut-off current	$I_{CBO}$	$V_{CB}=12\text{V}$ , $I_E=0$			0.05	$\mu\text{A}$
Collector cut-off current	$I_{CEO}$	$V_{CE}=12\text{V}$ , $I_B=0$			0.1	$\mu\text{A}$
Emitter cut-off current	$I_{EBO}$	$V_{EB}=3\text{V}$ , $I_C=0$			0.1	$\mu\text{A}$
DC current gain	$h_{FE(1)}$	$V_{CE}=5\text{V}$ , $I_C=1\text{mA}$	70		190	
Collector-emitter saturation voltage	$V_{CE(sat)}$	$I_C=10\text{mA}$ , $I_B=1\text{mA}$			0.5	V
Base-emitter saturation voltage	$V_{BE(sat)}$	$I_C=10\text{mA}$ , $I_B=1\text{mA}$			1.4	V
Transition frequency	$f_T$	$V_{CE}=5\text{V}$ , $I_C=5\text{mA}$ $f=400\text{MHz}$	600			MHz

# Typical Characteristics

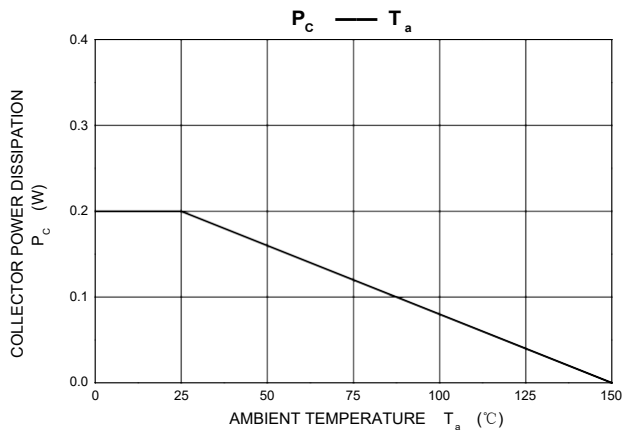
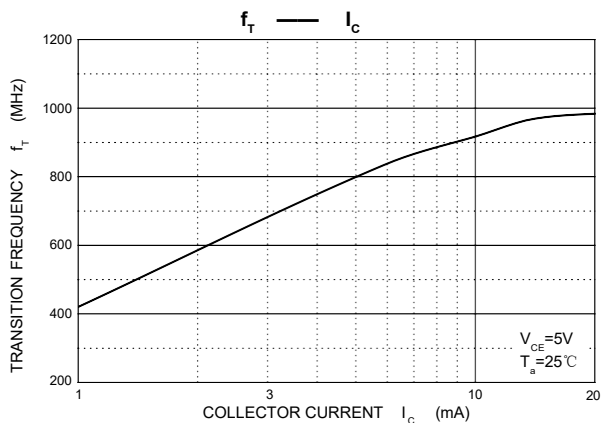
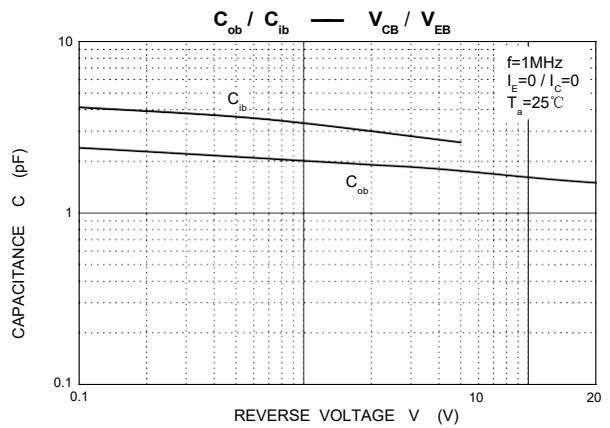
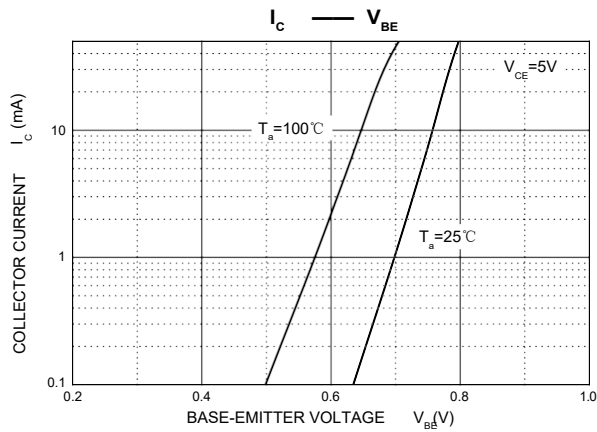
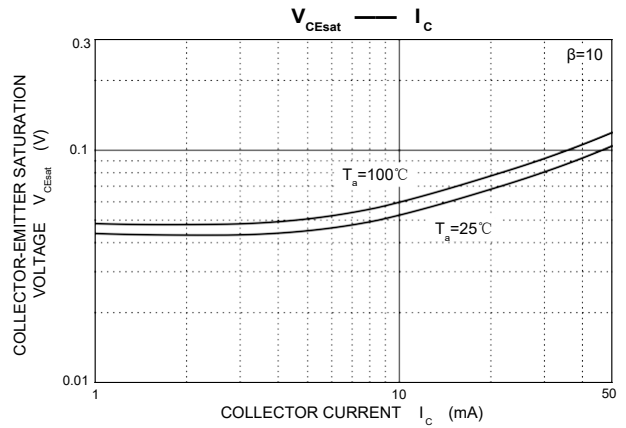
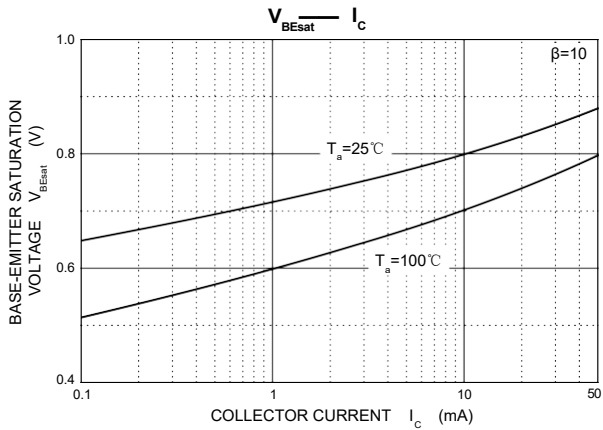
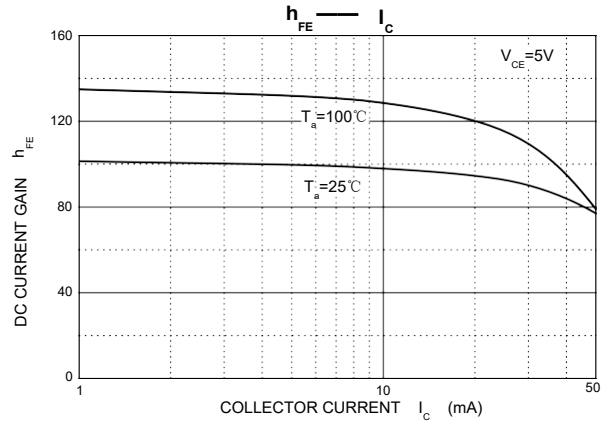
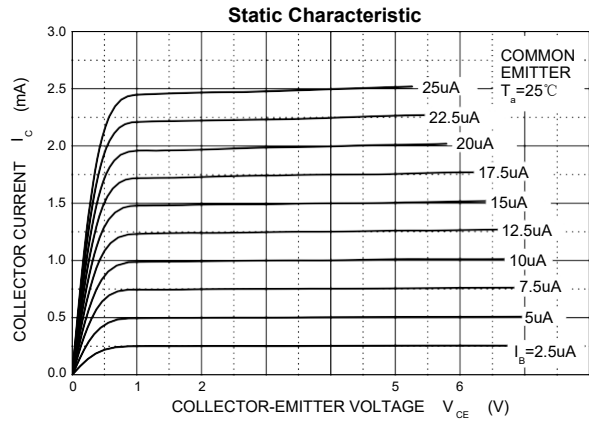

PACKAGE OUTLINE

Plastic surface mounted package; 3 leads

SOT-23

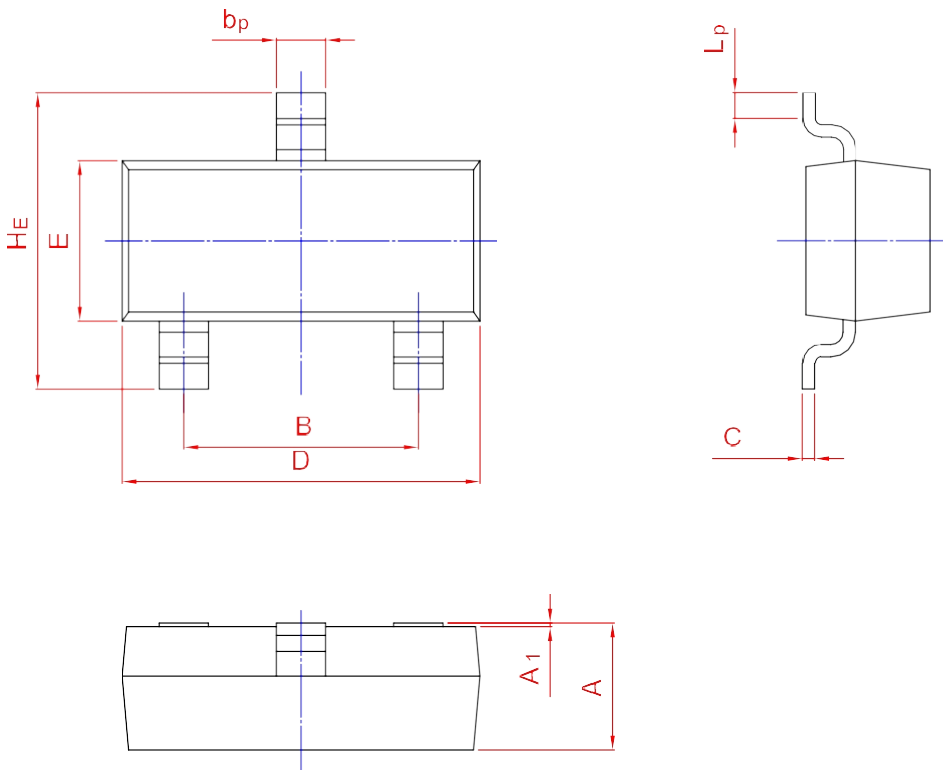
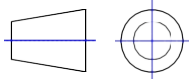

UNIT	A	B	bp	C	D	E	HE	A1	Lp
mm	1.40	2.04	0.50	0.19	3.10	1.65	3.00	0.100	0.50
	0.95	1.78	0.35	0.08	2.70	1.20	2.20	0.013	0.20

## DISCLAIMER

- Before you use our Products, you are requested to carefully read this document and fully understand its contents. BLUECOLOUR shall not be in any way responsible or liable for failure, malfunction or accident arising from the use of any BLUECOLOUR's Products against warning, caution or note contained in this document.
- All information contained in this document is current as of the issuing date and subject to change without any prior notice. Before purchasing or using BLUECOLOUR's Products, please confirm the latest information with a BLUECOLOUR sales representative.