

SOT-23 Plastic-Encapsulate Transistors

DTD123YCA DIGITAL TRANSISTOR (NPN)

FEATURES

- Built-in bias resistors enable the configuration of an inverter circuit without connecting external input resistors(see equivalent circuit)
- The bias resistors consist of thin-film resistors with complete isolation to allow negative biasing of the input.They also have the advantage of almost completely eliminating parasitic effects
- Only the on/off conditions need to be set for operation, making device design easy

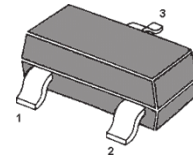

1.Base (IN) 2.Emitter (GND)
3.Collector (OUT)
SOT-23 Plastic Package

MARKING: F62

MAXIMUM RATINGS(Ta=25°C unless otherwise noted)

Symbol	Parameter	Limits	Unit
V _{CC}	Supply Voltage	50	V
V _{IN}	Input Voltage	-5~+12	V
I _O	Output Current	500	mA
P _D	Power Dissipation	200	mW
T _J	Junction Temperature	150	°C
T _{stg}	Storage Temperature	-55~+150	°C

Equivalent Circuit

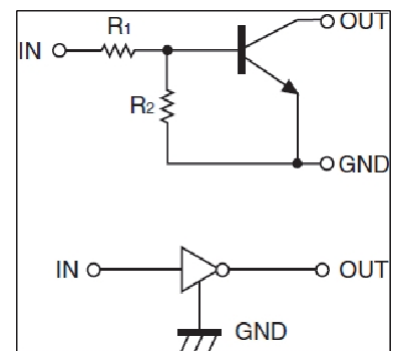

ELECTRICAL CHARACTERISTICS (Ta=25°C unless otherwise specified)

Parameter	Symbol	Conditions	Min	Typ	Max	Unit
Input voltage	V _{I(off)}	V _{CC} =5V, I _O =100μA	0.3			V
	V _{I(on)}	V _O =0.3V, I _O =20mA			2	V
Output voltage	V _{O(on)}	I _O /I _I =50mA/2.5mA		0.1	0.3	V
Input current	I _I	V _I =5V			3.6	mA
Output current	I _{O(off)}	V _{CC} =50V, V _I =0			0.5	μA
DC current gain	G _I	V _O =5V, I _O =50mA	56			
Input resistance	R ₁		1.54	2.2	2.86	kΩ
Resistance ratio	R ₂ /R ₁		3.6	4.5	5.5	
Transition frequency	f _T	V _O =10V, I _O =5mA, f=100MHz		200		MHz

Typical Characteristics

Fig.1 Input Voltage vs. Output Current (ON Characteristics)

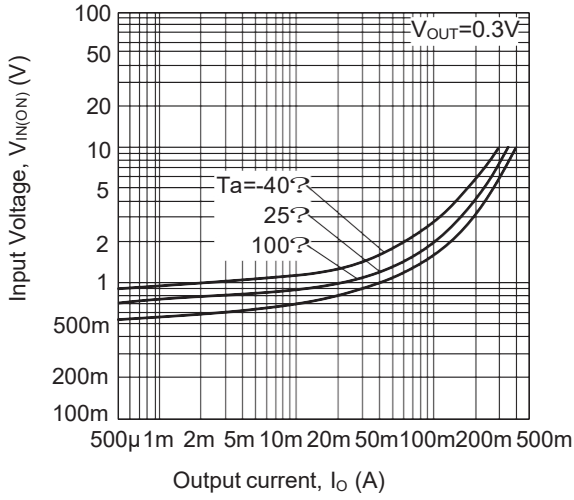

Fig.2 Output Current vs. Input Voltage (OFF Characteristics)

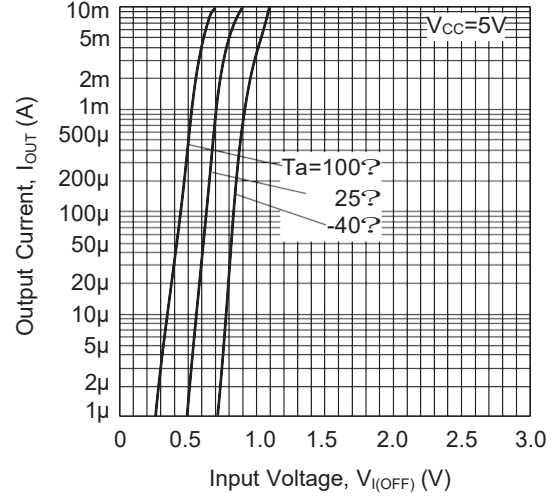

Fig.3 DC Current Gain vs. Output Current

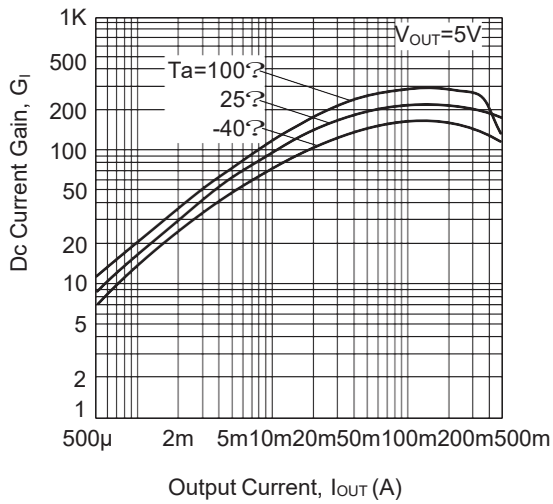
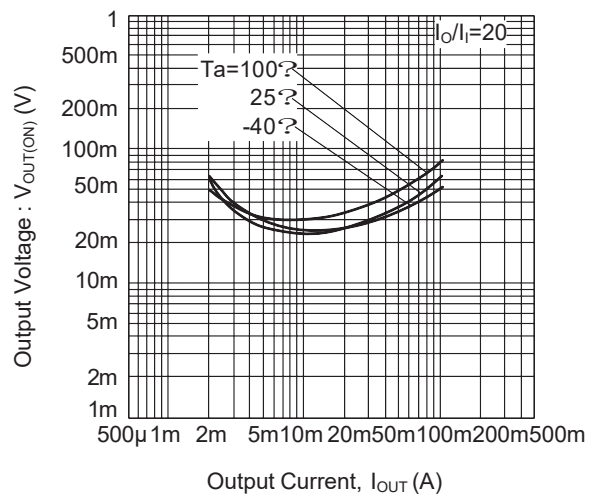

Fig.4 Output Voltage vs. Output Current



PACKAGE OUTLINE

Plastic surface mounted package; 3 leads

SOT-23

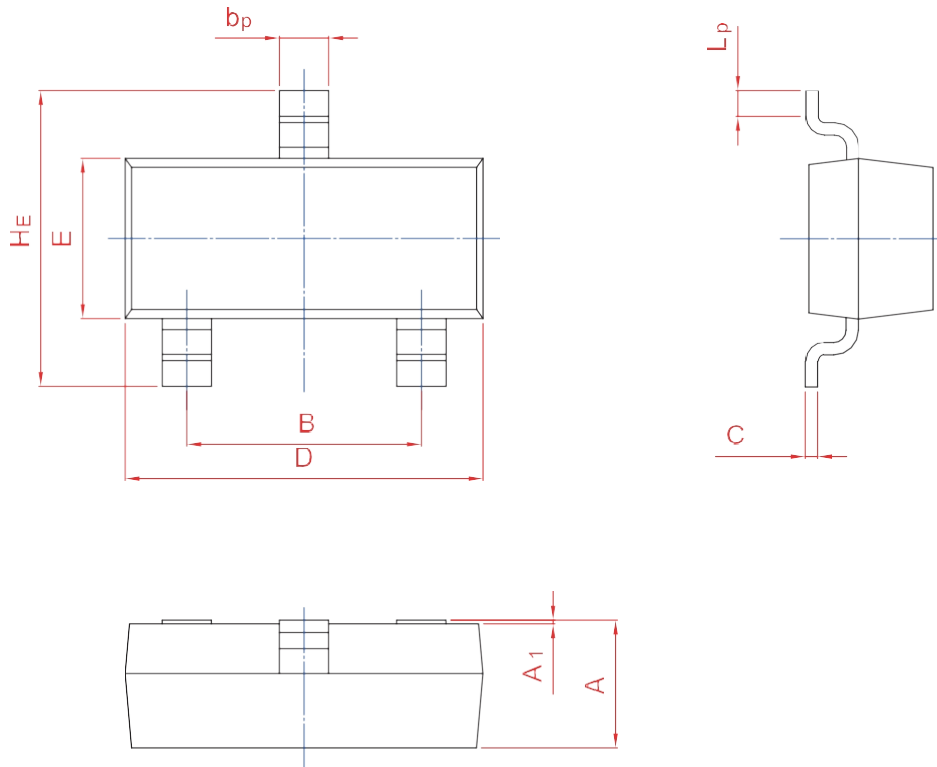
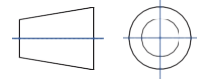

UNIT	A	B	bp	C	D	E	HE	A1	Lp
mm	1.40 0.95	2.04 1.78	0.50 0.35	0.19 0.08	3.10 2.70	1.65 1.20	3.00 2.20	0.100 0.013	0.50 0.20