

MMBTA14 NPN Silicon Epitaxial Planar Transistors

FEATURES

Darlington Amplifier

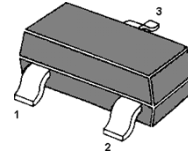

Marking : K3D

1 .Base 2.Emitter 3.Collector
SOT-23 Plastic Package

Absolute Maximum Ratings ($T_a=25\text{ }^\circ\text{C}$)

Parameter	Symbol	Value	Unit
Collector Emitter Voltage	V_{CES}	30	V
Collector Base Voltage	V_{CBO}	30	V
Emitter Base Voltage	V_{EBO}	10	V
Collector Current	I_C	500	mA
Power Dissipation	P_{tot}	300	mW
Junction Temperature	T_j	150	$^\circ\text{C}$
Storage Temperature Range	T_s	-55 to +150	$^\circ\text{C}$

Characteristics at $T_{amb}=25\text{ }^\circ\text{C}$

Parameter	Symbol	Min.	Max.	Unit
DC Current Gain				
at $V_{CE}=5\text{V}$, $I_C=10\text{mA}$	h_{FE}	10000	-	-
at $V_{CE}=5\text{V}$, $I_C=100\text{mA}$	h_{FE}	20000	-	-
Collector Emitter Breakdown Voltage				
at $I_C=100\mu\text{A}$	$V_{(BR)CES}$	30	-	V
Collector Cutoff Current				
at $V_{CB}=30\text{V}$	I_{CBO}	-	100	nA
Emitter Cutoff Current				
at $V_{EB}=10\text{V}$	I_{EBO}	-	100	nA
Collector Emitter Saturation Voltage				
at $I_C=100\text{mA}$, $I_B=0.1\text{mA}$	$V_{CE(sat)}$	-	1.5	V
Base Emitter On Voltage				
at $I_C=100\text{mA}$, $V_{CE}=5\text{V}$	$V_{BE(on)}$	-	2	V
Current Gain Bandwidth Product				
at $V_{CE}=5\text{V}$, $I_C=10\text{mA}$, $f=100\text{MHz}$	f_T	125	-	MHz

Typical Characteristics

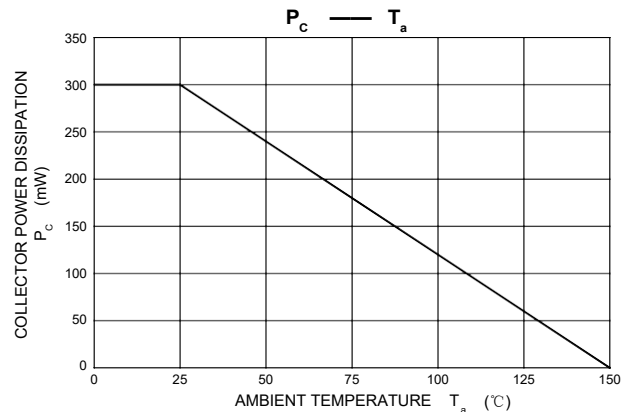
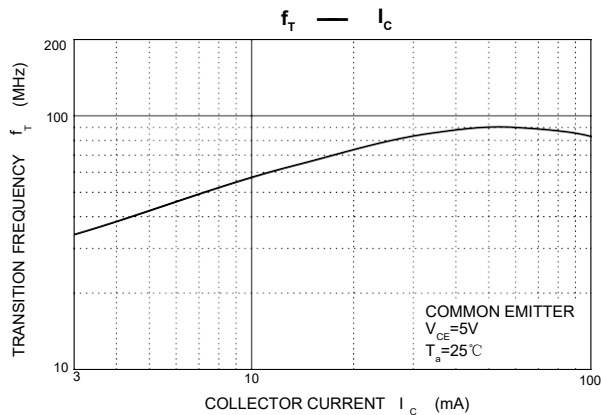
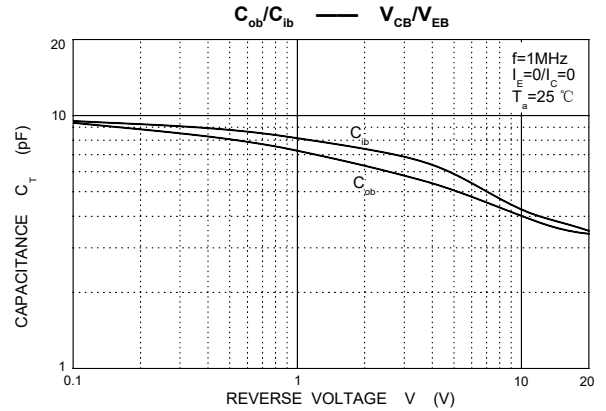
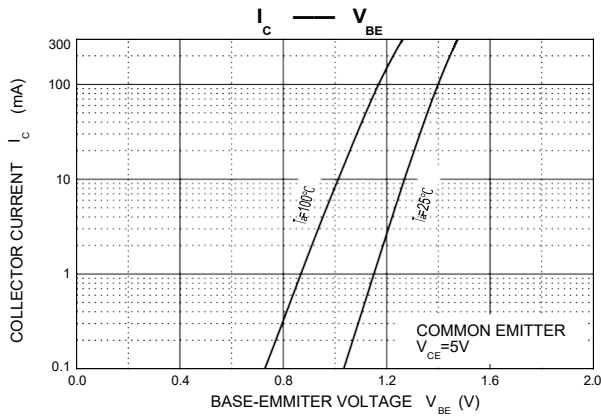
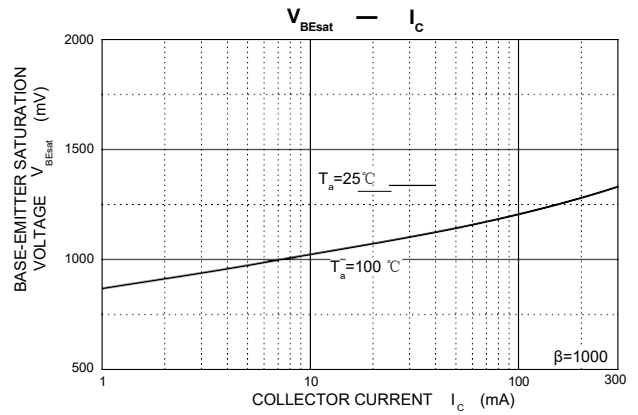
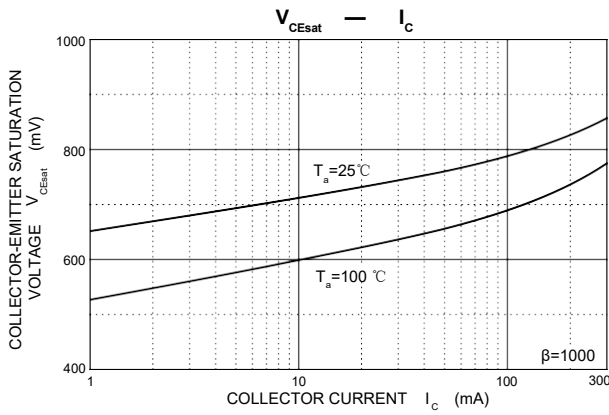
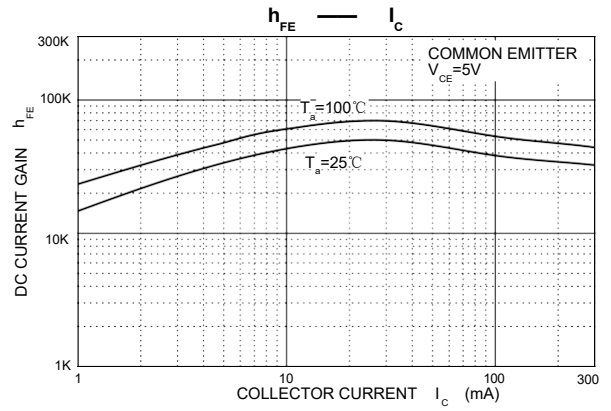
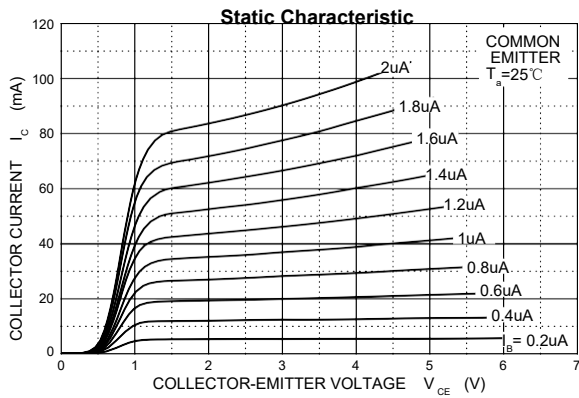

PACKAGE OUTLINE

Plastic surface mounted package; 3 leads

SOT-23

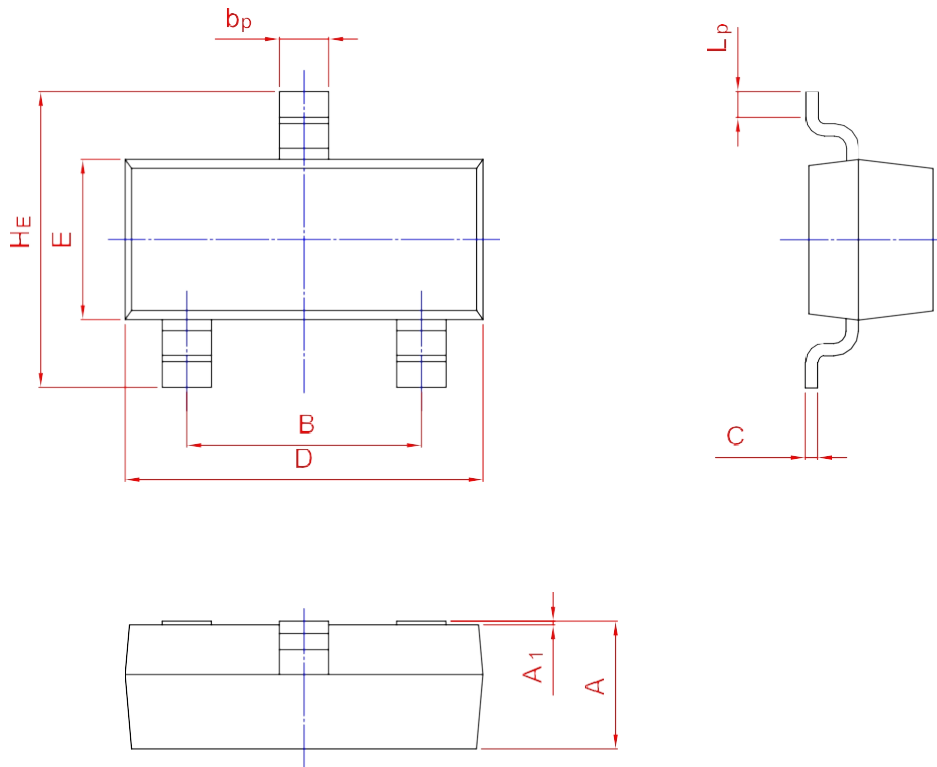
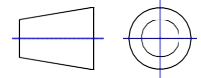

UNIT	A	B	bp	C	D	E	HE	A1	Lp
mm	1.40	2.04	0.50	0.19	3.10	1.65	3.00	0.100	0.50
	0.95	1.78	0.35	0.08	2.70	1.20	2.20	0.013	0.20