

BC3404

 N-Channel Enhancement Mode Field Effect Transistor

SOT-23 Plastic-Encapsulate MOSFETS

DESCRIPTION

The BC3404 use advanced trench technology to provide excellent $R_{DS(ON)}$ and low gate charge. This device is suitable for use as a load switch or in PWM applications. The source leads are separated to allow a Kelvin connection to the source, which may be used to bypass the source inductance.

MARKING: R4

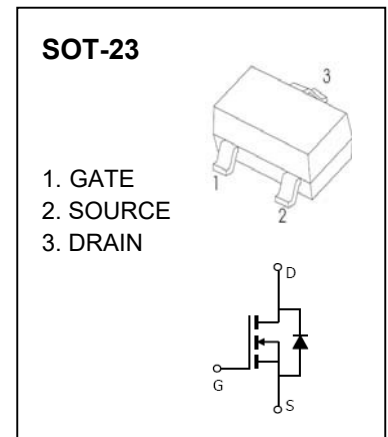

Maximum ratings ($T_a=25^\circ\text{C}$ unless otherwise noted)

Parameter	Symbol	Value	Unit
Drain-source voltage	V_{DS}	30	V
Gate-source voltage	V_{GS}	± 20	V
Continuous drain current ($t \leq 10\text{s}$)	I_D	5.8	A
Pulsed drain current *	I_{DM}	30	A
Thermal resistance from junction to ambient	$R_{\theta JA}$	357	$^\circ\text{C}/\text{W}$
Junction temperature	T_J	150	$^\circ\text{C}$
Storage temperature	T_{stg}	-55~ 150	$^\circ\text{C}$

* Repetitive rating : Pulse width limited by maximum junction temperature.

Electrical characteristics ($T_a=25^{\circ}\text{C}$ unless otherwise noted)

Parameter	Symbol	Test Condition	Min	Typ	Max	Units
STATIC PARAMETERS						
Drain-source breakdown voltage	$V_{(BR)DSS}$	$V_{GS} = 0V, I_D = 250\mu A$	30			V
Zero gate voltage drain current	I_{DSS}	$V_{DS} = 30V, V_{GS} = 0V$			1	μA
Gate-body leakage current	I_{GSS}	$V_{GS} = \pm 20V, V_{DS} = 0V$			± 100	nA
Gate threshold voltage	$V_{GS(th)}$	$V_{DS} = V_{GS}, I_D = 250\mu A$	1		3	V
Drain-source on-resistance (note 1)	$R_{DS(on)}$	$V_{GS} = 10V, I_D = 5.8A$			30	$m\Omega$
		$V_{GS} = 4.5V, I_D = 4.8A$			42	$m\Omega$
Forward transconductance (note 1)	g_{FS}	$V_{DS} = 5V, I_D = 5.8A$	5			S
Diode forward voltage	V_{SD}	$I_S = 1A$			1	V
DYNAMIC PARAMETERS (note 2)						
Input capacitance	C_{iss}	$V_{DS} = 15V, V_{GS} = 0V, f = 1MHz$			820	pF
Output capacitance	C_{oss}			118		pF
Reverse transfer capacitance	C_{riss}			85		pF
Gate resistance	R_g	$V_{DS} = 0V, V_{GS} = 0V, f = 1MHz$			1.5	Ω
SWITCHING PARAMETERS (note 2)						
Turn-on delay time	$t_{d(on)}$	$V_{GS} = 10V, V_{DS} = 15V,$ $R_L = 2.6\Omega, R_{GEN} = 3\Omega$			6.5	ns
Turn-on rise time	t_r			3.1		ns
Turn-off delay time	$t_{d(off)}$			15.1		ns
Turn-off fall time	t_f			2.7		ns

Note :

1. Pulse Test : Pulse width $\leq 300\mu s$, duty cycle $\leq 0.5\%$.
2. These parameters have no way to verify.

Typical Characteristics

Output Characteristics

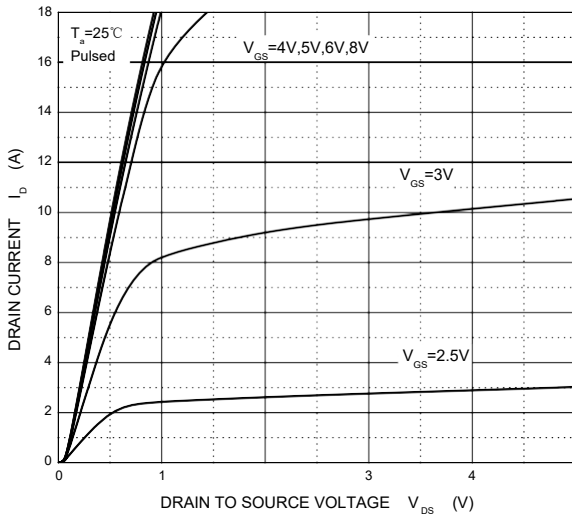

Transfer Characteristics

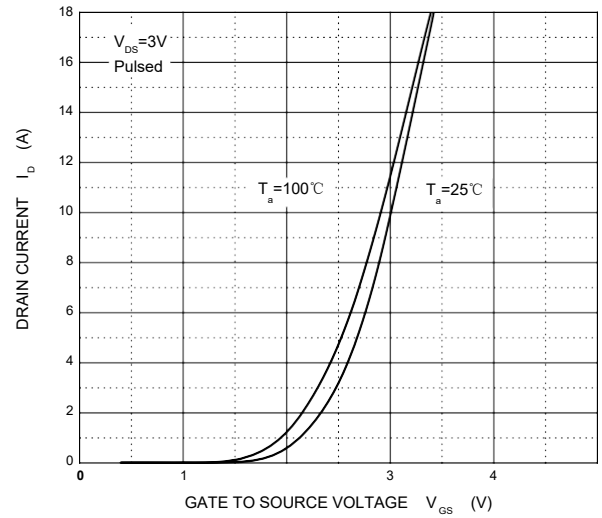

$R_{DS(ON)}$ — I_D

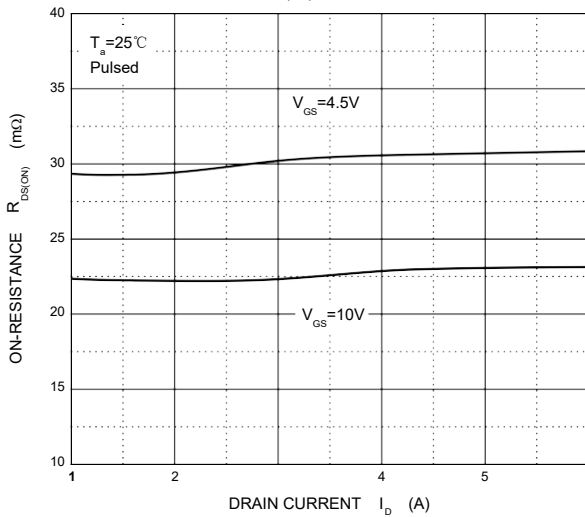

$R_{DS(ON)}$ — V_{GS}

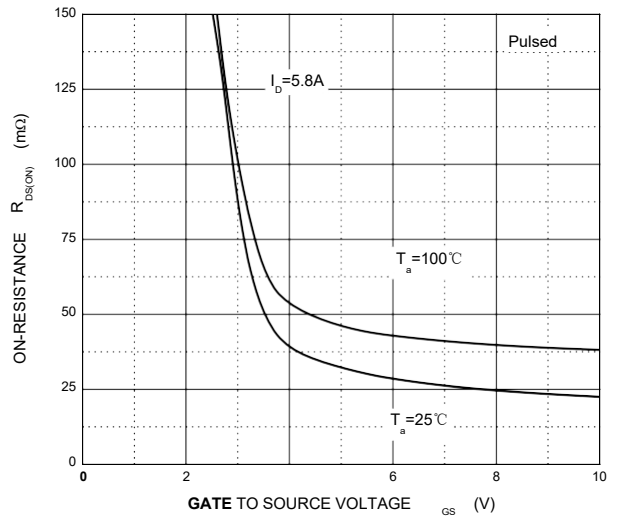

I_S — V_{SD}

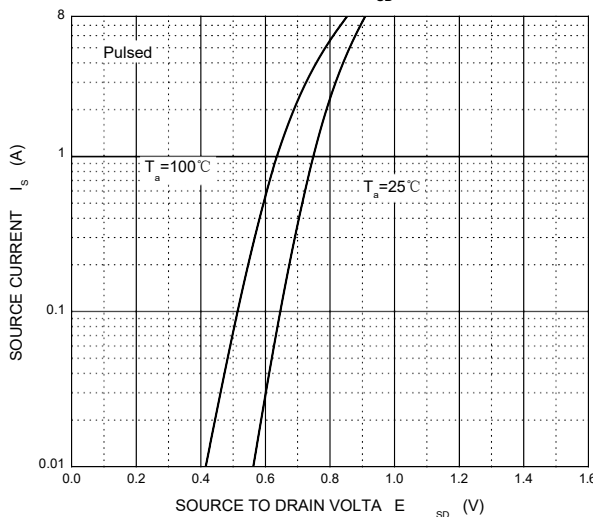

Threshold Voltage

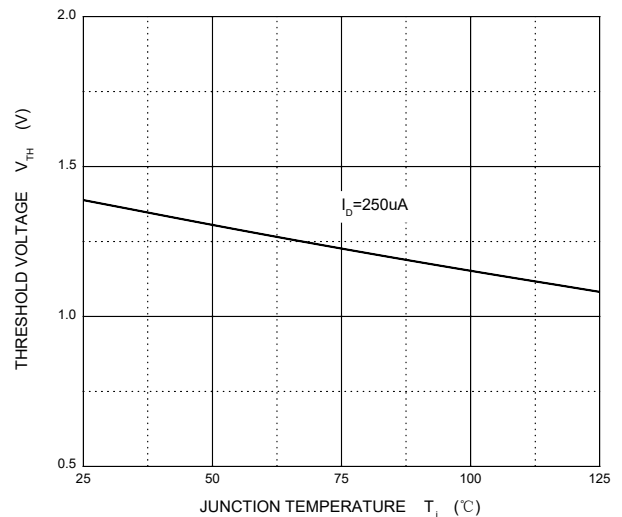

PACKAGE OUTLINE

Plastic surface mounted package; 3 leads

SOT-23

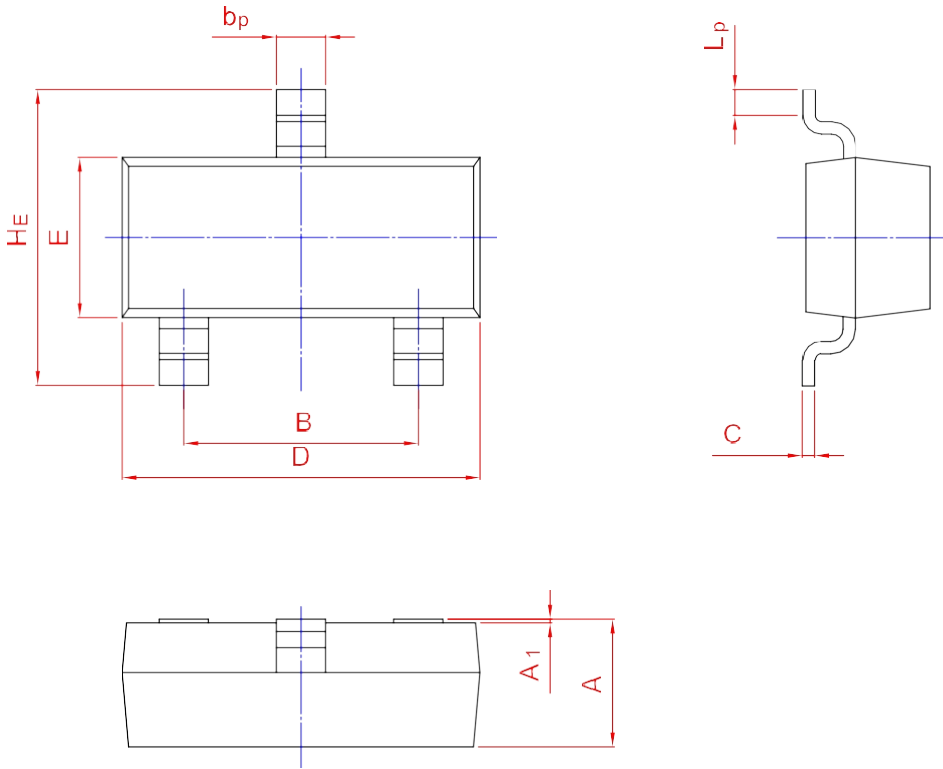
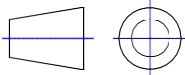

UNIT	A	B	b _p	C	D	E	H _E	A ₁	L _p
mm	1.40	2.04	0.50	0.19	3.10	1.65	3.00	0.100	0.50
	0.95	1.78	0.35	0.08	2.70	1.20	2.20	0.013	0.20