

MM1Z2B4~MM1ZB75 SILICON PLANAR ZENER DIODES

Features

- Power Dissipation: 500 mW
- Zener Voltage Tolerance: $\pm 2\%$

PINNING

PIN	DESCRIPTION
1	Cathode
2	Anode

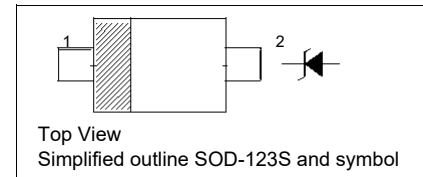

Absolute Maximum Ratings ($T_a = 25^\circ\text{C}$)

Parameter	Symbol	Value	Unit
Power Dissipation	P_{tot}	500	mW
Junction Temperature	T_J	150	$^\circ\text{C}$
Storage Temperature Range	T_{Stg}	- 55 to + 150	$^\circ\text{C}$

Characteristics at $T_a = 25^\circ\text{C}$

Parameter	Symbol	Max.	Unit
Thermal Resistance Junction to Ambient Air	R_{thJA}	340	$^\circ\text{C}/\text{W}$
Forward Voltage at $I_F = 10 \text{ mA}$	V_F	0.9	V

Characteristics at Ta = 25 °C

Type	Marking Code	Zener Voltage Range ¹⁾			Dynamic Impedance		Reverse Leakage Current	
		V _{znom} V	I _{ZT} for V _{ZT}		Z _{ZT} (Max.) Ω	at I _Z mA	I _R (Max.) μA	at V _R V
			mA	V				
MM1Z2B4	5Y1	2.4	5	2.352...2.448	100	5	120	1
MM1Z2B7	5Z1	2.7	5	2.646...2.754	110	5	120	1
MM1Z3B0	6A1	3.0	5	2.94...3.06	120	5	50	1
MM1Z3B3	6B1	3.3	5	3.234...3.366	130	5	20	1
MM1Z3B6	6C1	3.6	5	3.528...3.672	130	5	10	1
MM1Z3B9	6D1	3.9	5	3.822...3.978	130	5	5	1
MM1Z4B3	6E1	4.3	5	4.214...4.386	130	5	5	1
MM1Z4B7	6F1	4.7	5	4.606...4.794	130	5	2	1
MM1Z5B1	6G1	5.1	5	4.998...5.202	130	5	2	1.5
MM1Z5B6	6H1	5.6	5	5.488...5.712	80	5	1	2.5
MM1Z6B2	6J1	6.2	5	6.076...6.324	50	5	1	3
MM1Z6B8	6K1	6.8	5	6.664...6.936	30	5	0.5	3.5
MM1Z7B5	6L1	7.5	5	7.35...7.65	30	5	0.5	4
MM1Z8B2	6M1	8.2	5	8.036...8.364	30	5	0.5	5
MM1Z9B1	6N1	9.1	5	8.918...9.282	30	5	0.5	6
MM1ZB10	6P1	10	5	9.8...10.2	30	5	0.1	7
MM1ZB11	6Q1	11	5	10.78...11.22	30	5	0.1	8
MM1ZB12	6R1	12	5	11.76...12.24	35	5	0.1	9
MM1ZB13	6S1	13	5	12.74...13.26	35	5	0.1	10
MM1ZB15	6T1	15	5	14.7...15.3	40	5	0.1	11
MM1ZB16	6U1	16	5	15.68...16.32	40	5	0.1	12
MM1ZB18	6W1	18	5	17.64...18.36	45	5	0.1	13
MM1ZB20	6X1	20	5	19.6...20.4	50	5	0.1	15
MM1ZB22	6Y1	22	5	21.56...22.44	55	5	0.1	17
MM1ZB24	6Z1	24	5	23.52...24.48	60	5	0.1	19
MM1ZB27	7A1	27	5	26.46...27.54	70	2	0.1	21
MM1ZB30	7B1	30	5	29.4...30.6	80	2	0.1	23
MM1ZB33	7C1	33	5	32.34...33.66	80	2	0.1	25
MM1ZB36	7D1	36	5	35.28...36.72	90	2	0.1	27
MM1ZB39	7E1	39	2.5	38.22...39.78	100	2	2	30
MM1ZB43	7F1	43	2.5	42.14...43.86	130	2	2	33
MM1ZB47	7G1	47	2.5	46.06...47.94	150	2	2	36
MM1ZB51	7H1	51	2.5	49.98...52.02	180	2	1	39
MM1ZB56	7J1	56	2.5	54.88...57.12	180	2	1	43
MM1ZB62	7K1	62	2.5	60.76...63.24	200	2	0.2	47
MM1ZB68	7L1	68	2.5	66.64...69.36	250	2	0.2	52
MM1ZB75	7M1	75	2.5	73.5...76.5	300	2	0.2	57

¹⁾V_Z is tested with pulses (20 ms).

PACKAGE OUTLINE

Plastic surface mounted package; 2 leads

SOD-123S

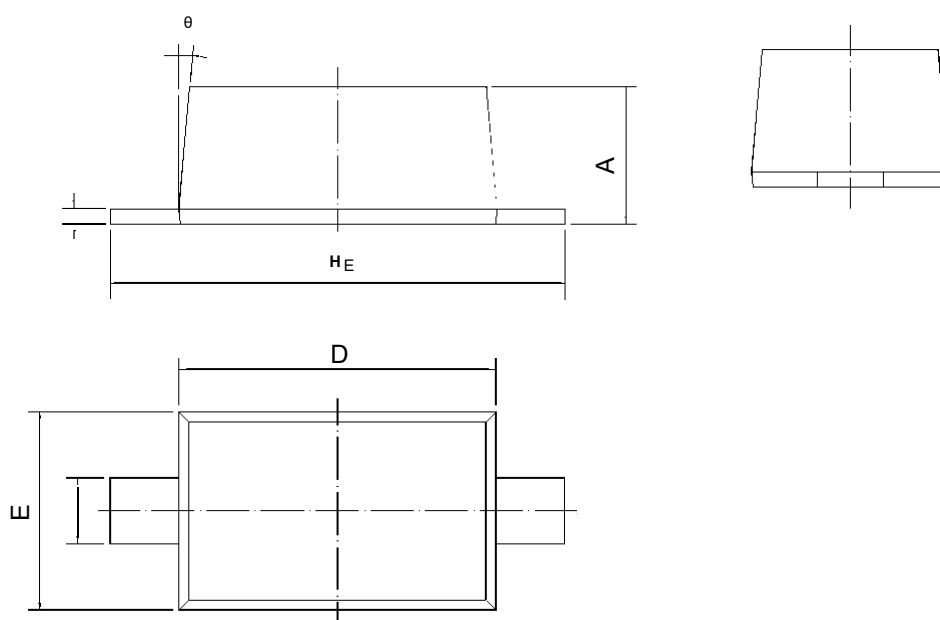

UNIT	A	b_p	c	D	E	H_E	θ
mm	0.975 0.875	0.6 0.5	0.135 0.100	2.7 2.6	1.65 1.55	3.85 3.55	5°