

BZX84C...CA Series SILICON PLANAR ZENER DIODES

Features

- Zener breakdown voltage range - 2.4 V to 75 V
- Package designed for optimal automated board assembly
- Small package size for high density applications

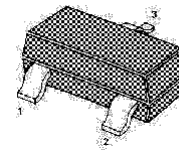

1. Cathode 2. Cathode 3. Anode
SOT-23 Plastic Package

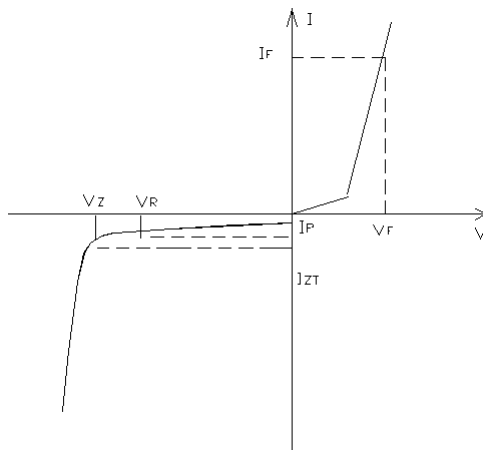

Zener Voltage Regulation

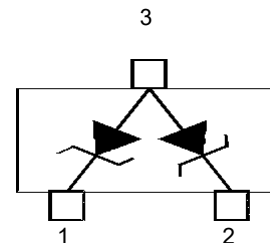

Absolute Maximum Ratings ($T_a = 25^{\circ}\text{C}$)

Parameter	Symbol	Value	Unit
Power Dissipation	P_D	300	mW
Thermal Resistance, Junction to Ambient ¹⁾	$R_{\theta JA}$	417	$^{\circ}\text{C/W}$
Junction and Storage Temperature Range	T_j, T_s	- 65 to + 150	$^{\circ}\text{C}$

¹⁾ Alumina = 0.4 X 0.3 X 0.024 in, 99.5% alumina

Characteristics at $T_a = 25^{\circ}\text{C}$

Parameter	Symbol	Max.	Unit
Forward Voltage at $I_F = 10 \text{ mA}$	V_F	0.9	V

Electrical Characteristics ($T_a = 25^\circ\text{C}$ unless otherwise noted)

Type	Marking Code	Zener Voltage Range ¹⁾				Dynamic Resistance				Reverse Leakage Current	
		V_Z			at I_{ZT}	Z_{ZT}	at I_{ZT}	Z_{ZK}	at I_{ZK}	I_R	at V_R
		Nom. (V)	Min. (V)	Max. (V)	mA	Max. (Ω)	mA	Max. (Ω)	mA	Max. (μA)	V
BZX84C2V4CA	7H	2.4	2.2	2.6	5	100	5	600	1	50	1
BZX84C2V7CA	7J	2.7	2.5	2.9	5	100	5	600	1	20	1
BZX84C3V0CA	MR	3.0	2.8	3.2	5	95	5	600	1	10	1
BZX84C3V3CA	MX	3.3	3.1	3.5	5	95	5	600	1	5	1
BZX84C3V6CA	MY	3.6	3.4	3.8	5	90	5	600	1	5	1
BZX84C3V9CA	MZ	3.9	3.7	4.1	5	90	5	600	1	3	1
BZX84C4V3CA	NA	4.3	4	4.6	5	90	5	600	1	3	1
BZX84C4V7CA	NB	4.7	4.4	5	5	80	5	500	1	3	2
BZX84C5V1CA	NC	5.1	4.8	5.4	5	60	5	480	1	2	2
BZX84C5V6CA	ND	5.6	5.2	6	5	40	5	400	1	1	2
BZX84C6V2CA	NE	6.2	5.8	6.6	5	10	5	150	1	3	4
BZX84C6V8CA	NF	6.8	6.4	7.2	5	15	5	80	1	2	4
BZX84C7V5CA	NH	7.5	7	7.9	5	15	5	80	1	1	5
BZX84C8V2CA	NJ	8.2	7.7	8.7	5	15	5	80	1	0.7	5
BZX84C9V1CA	NK	9.1	8.5	9.6	5	15	5	100	1	0.5	6
BZX84C10CA	NM	10	9.4	10.6	5	20	5	150	1	0.2	7
BZX84C11CA	NN	11	10.4	11.6	5	20	5	150	1	0.1	8
BZX84C12CA	NP	12	11.4	12.7	5	25	5	150	1	0.1	8
BZX84C13CA	NX	13	12.4	14.1	5	30	5	170	1	0.1	8
BZX84C15CA	NY	15	14.3	15.8	5	30	5	200	1	0.05	10.5
BZX84C16CA	NZ	16	15.3	17.1	5	40	5	200	1	0.05	11.2
BZX84C18CA	PA	18	16.8	19.1	5	45	5	225	1	0.05	12.6
BZX84C20CA	PB	20	18.8	21.2	5	55	5	225	1	0.05	14
BZX84C22CA	PC	22	20.8	23.3	5	55	5	250	1	0.05	15.4
BZX84C24CA	PD	24	22.8	25.6	5	70	5	250	1	0.05	16.8
BZX84C27CA	PE	27	25.1	28.9	2	80	2	300	0.5	0.05	18.9
BZX84C30CA	PF	30	28	32	2	80	2	325	0.5	0.05	21
BZX84C33CA	PH	33	31	35	2	80	2	350	0.5	0.05	23.1
BZX84C36CA	PJ	36	34	38	2	90	2	350	0.5	0.05	25.2
BZX84C39CA	PM	39	37	41	2	130	2	375	0.5	0.05	27.3
BZX84C43CA	PN	43	40	46	2	150	2	375	0.5	0.05	30.1
BZX84C47CA	PP	47	44	50	2	170	2	375	0.5	0.05	32.9
BZX84C51CA	7K	51	48	54	2	180	2	400	0.5	0.05	35.7
BZX84C56CA	7M	56	52	60	2	200	2	425	0.5	0.05	39.2
BZX84C62CA	7N	62	58	66	2	215	2	450	0.5	0.05	43.4
BZX84C68CA	7P	68	64	72	2	240	2	475	0.5	0.05	47.6
BZX84C75CA	7R	75	70	79	2	255	2	500	0.5	0.05	52.5

¹⁾ Tested with pulses $t_p = 20$ ms.

Typical Characteristics

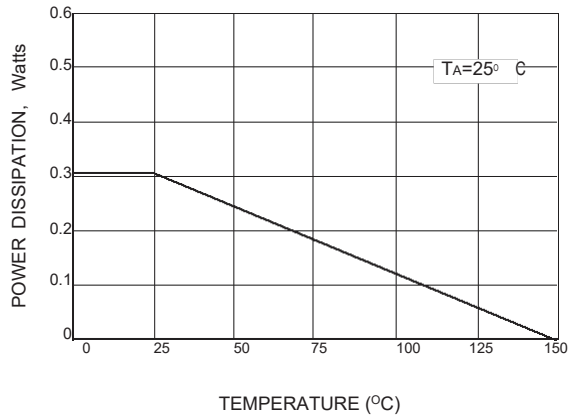

Fig.1 STEADY STATE POWER DERATING

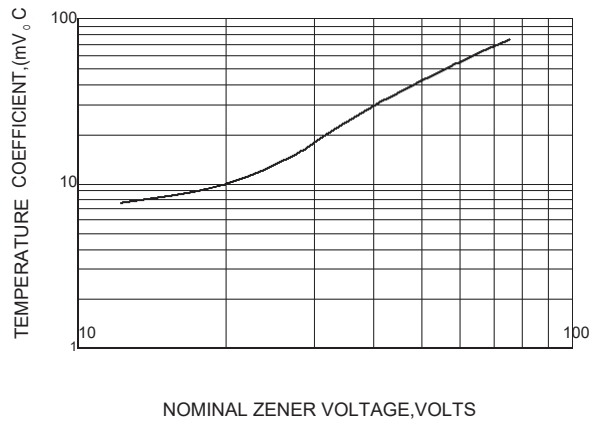

Fig.2 TEMPERATURE COEFFICIENTS

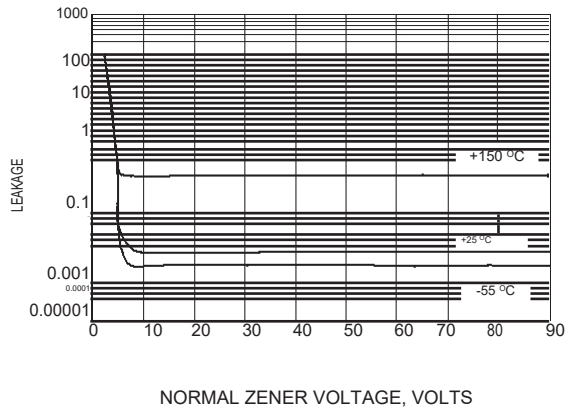

Fig.3 TYPICAL LEAKAGE CURRENT

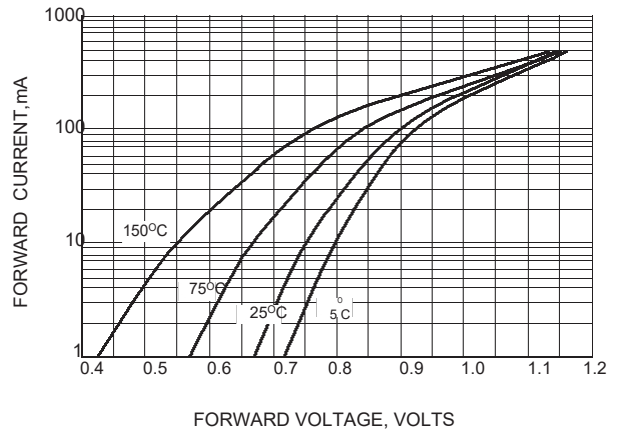

Fig.4 TYPICAL FORWARD VOLTAGE

PACKAGE OUTLINE

Plastic surface mounted package; 3 leads

SOT-23

