

SOD-123 Plastic-Encapsulate Diodes

TVS1ZxxA Series Zener Transient Voltage Suppressor

DESCRIPTION

The TVS1ZxxA Series is designed to protect voltage sensitive components from high voltage, high energy transients. Excellent clamping capability, high surge capability, low zener impedance and fast response time. Because of its small size, it is ideal for use in cellular phones, portable devices, business machines, power supplies and many other industrial/consumer applications.

Features

- Stand-off Voltage: 5 – 170 Volts
- Peak Power – 200 Watts @ 1 ms (SMF5.0A – SMF58A)
– 175 Watts @ 1 ms (SMF60A – SMF170A)
- Maximum Clamp Voltage @ Peak Pulse Current
- Low Leakage
- Response Time is Typically < 1 ns
- ESD Rating of Class 3 (> 16 kV) per Human Body Model
IEC61000-4-2 Level 4 ESD Protection
IEC61000-4-4 40 A ESD Protection

PINNING

PIN	DESCRIPTION
1	Cathode
2	Anode

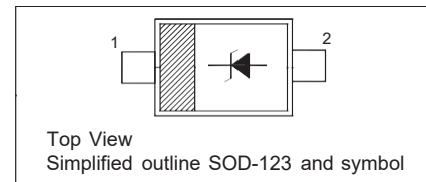

MAXIMUM RATINGS

Rating	Symbol	Value	Unit
Maximum P_{pk} Dissipation (PW=10/1000 μ s) (Note 1) SMF60A – SMF170A	P_{pk}	175	W
Maximum P_{pk} Dissipation (PW=10/1000 μ s) (Note 1) SMF5.0A – SMF58A	P_{pk}	200	W
Maximum P_{pk} Dissipation @ $T_A = 25^\circ\text{C}$, (PW=8/20 μ s) (Note 2)	P_{pk}	1000	W
DC Power Dissipation @ $T_A = 25^\circ\text{C}$ (Note 3) Derate above 25°C	P_D	385	mW
Thermal Resistance, Junction-to-Ambient (Note 3)	$R_{\theta JA}$	4.0	$\text{mW}/^\circ\text{C}$
Thermal Resistance, Junction-to-Lead (Note 3)	$R_{\theta Jcathode}$	325	$^\circ\text{C}/\text{W}$
Operating and Storage Temperature Range	T_J, T_{stg}	-55 to +150	$^\circ\text{C}$

1. Non-repetitive current pulse at $T_A = 25^\circ\text{C}$, per waveform of Figure 2.
2. Non-repetitive current pulse at $T_A = 25^\circ\text{C}$, per waveform of Figure 3.
3. Mounted with recommended minimum pad size, DC board FR-4.

ELECTRICAL CHARACTERISTICS ($T_A = 25^\circ\text{C}$ unless otherwise noted, $V_F = 3.5\text{ V Max. @ } I_F$ (Note 4) = 12 A)

Symbol	Parameter
I_{PP}	Maximum Reverse Peak Pulse Current
V_C	Clamping Voltage @ I_{PP}
V_{RWM}	Working Peak Reverse Voltage
I_R	Maximum Reverse Leakage Current @ V_{RWM}
V_{BR}	Breakdown Voltage @ I_T
I_T	Test Current
I_F	Forward Current
V_F	Forward Voltage @ I_F

4. 1/2 sine wave (or equivalent square wave), PW = 8.3 ms, duty cycle = 4 pulses per minute maximum.

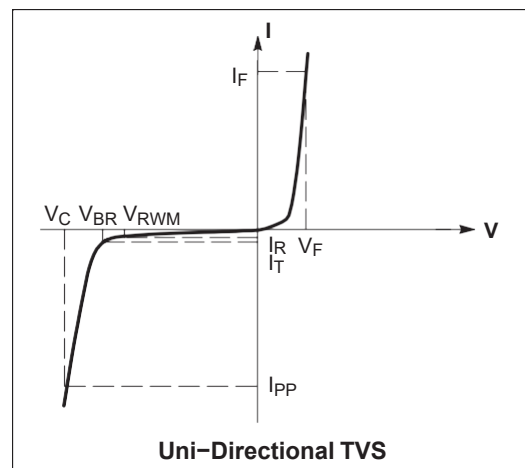

ELECTRICAL CHARACTERISTICS ($T_L = 30^\circ\text{C}$ unless otherwise noted, $V_F = 1.25$ Volts @ 200 mA)

Device*	Marking	V_{RWM} (V)	V_{BR} @ I_T (V) (Note 6)			I_T	I_R @ V_{RWM}	$V_C(\text{Max})$	$I_{PP}(\text{Max})$ (A)
		(Note 5)	Min	Nom	Max	(mA)	(μA)	(V)	(Note 7)
TVS1Z5.0A	FE	5	6.4	6.7	7	10	400	9.2	21.7
TVS1Z6.0A	FG	6	6.67	7.02	7.37	10	400	10.3	19.4
TVS1Z6.5A	FK	6.5	7.22	7.6	7.98	10	250	11.2	17.9
TVS1Z7.0A	FM	7	7.78	8.2	8.6	10	100	12	16.7
TVS1Z7.5A	FP	7.5	8.33	8.77	9.21	1	50	12.9	15.5
TVS1Z8.0A	FR	8	8.89	9.36	9.83	1	25	13.6	14.7
TVS1Z8.5A	FT	8.5	9.44	9.92	10.4	1	10	14.4	13.9
TVS1Z9.0A	FV	9	10	10.55	11.1	1	5	15.4	13.0
TVS1Z10A	FX	10	11.1	11.7	12.3	1	2.5	17	11.8
TVS1Z11A	FZ	11	12.2	12.85	13.5	1	2.5	18.2	11.0
TVS1Z12A	HE	12	13.3	14	14.7	1	2.5	19.9	10.1
TVS1Z13A	HG	13	14.4	15.15	15.9	1	1	21.5	9.3
TVS1Z14A	HK	14	15.6	16.4	17.2	1	1	23.2	8.6
TVS1Z15A	HM	15	16.7	17.6	18.5	1	1	24.4	8.2
TVS1Z16A	HP	16	17.8	18.75	19.7	1	1	26	7.7
TVS1Z17A	HR	17	18.9	19.9	20.9	1	1	27.6	7.2
TVS1Z18A	HT	18	20	21	22.1	1	1	29.2	6.8
TVS1Z20A	HV	20	22.2	23.35	24.5	1	1	32.4	6.2
TVS1Z22A	HX	22	24.4	25.6	26.9	1	1	35.5	5.6
TVS1Z24A	HZ	24	26.7	28.1	29.5	1	1	38.9	5.1
TVS1Z26A	JE	26	28.9	30.4	31.9	1	1	42.1	4.8
TVS1Z28A	JG	28	31.1	32.8	34.4	1	1	45.4	4.4
TVS1Z30A	JK	30	33.3	35.1	36.8	1	1	48.4	4.1
TVS1Z33A	JM	33	36.7	38.7	40.6	1	1	53.3	3.8
TVS1Z36A	JP	36	40	42.1	44.2	1	1	58.1	3.4
TVS1Z40A	JR	40	44.4	46.8	49.1	1	1	64.5	3.1
TVS1Z43A	JT	43	47.8	50.3	52.8	1	1	69.4	2.9
TVS1Z45A	JV	45	50	52.65	55.3	1	1	72.7	2.8
TVS1Z48A	JX	48	53.3	56.1	58.9	1	1	77.4	2.6
TVS1Z51A	JZ	51	56.7	59.7	62.7	1	1	82.4	2.4
TVS1Z54A	XE	54	60	63.15	66.3	1	1	87.1	2.3
TVS1Z58A	XG	58	64.4	67.8	71.2	1	1	93.6	2.1
TVS1Z60A	XK	60	66.7	70.2	73.7	1	1	96.8	1.8
TVS1Z64A	XM	64	71.1	74.85	78.6	1	1	103	1.7
TVS1Z70A	XP	70	77.8	81.9	86	1	1	113	1.5
TVS1Z75A	XR	75	83.3	87.7	92.1	1	1	121	1.4
TVS1Z78A	XT	78	86.7	91.25	95.8	1	1	126	1.4
TVS1Z85A	XV	85	94.4	99.2	104	1	1	137	1.3
TVS1Z90A	XX	90	100	105.5	111	1	1	146	1.2
TVS1Z100A	XZ	100	111	117	123	1	1	162	1.1
TVS1Z110A	TE	110	122	128.5	135	1	1	177	1.0
TVS1Z120A	TG	120	133	140	147	1	1	193	0.9
TVS1Z130A	TK	130	144	151.5	159	1	1	209	0.8
TVS1Z150A	TM	150	167	176	185	1	1	243	0.7
TVS1Z160A	TP	160	178	187.5	197	1	1	259	0.7
TVS1Z170A	TR	170	189	199	209	1	1	275	0.6

5. A transient suppressor is normally selected according to the Working Peak Reverse Voltage (V_{RWM}) which should be equal to or greater than the DC or continuous peak operating voltage level.
6. V_{BR} measured at pulse test current I_T at ambient temperature of 25°C .
7. Surge current waveform per Figure 2 and derate per Figure 3.

Typical Characteristics

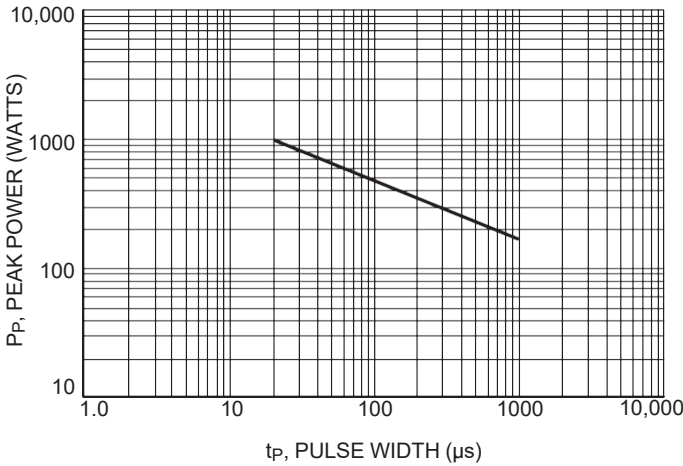

Figure 1. Pulse Rating Curve

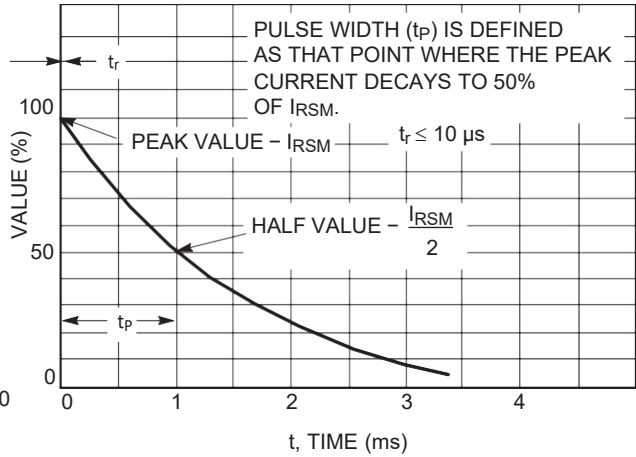

Figure 2. 10 X 1000 μs Pulse Waveform

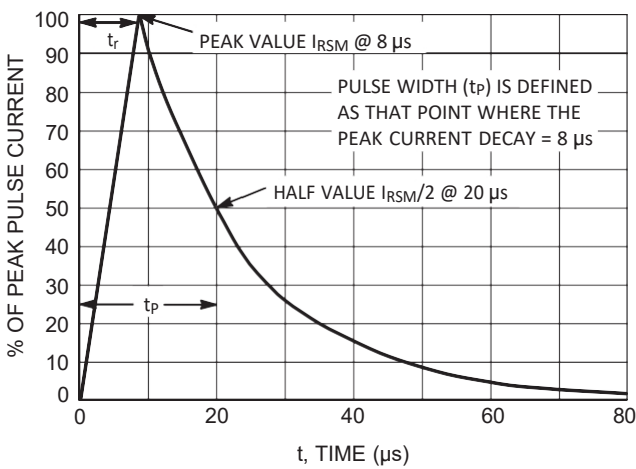

Figure 3. 8 X 20 μs Pulse Waveform

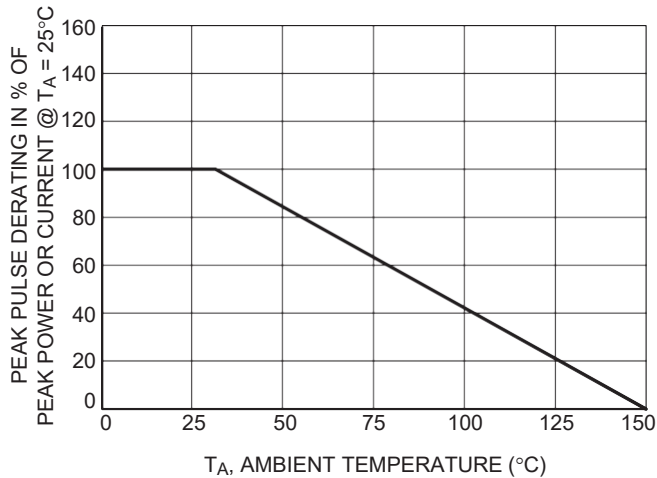

Figure 4. Pulse Derating Curve

Typical Characteristics

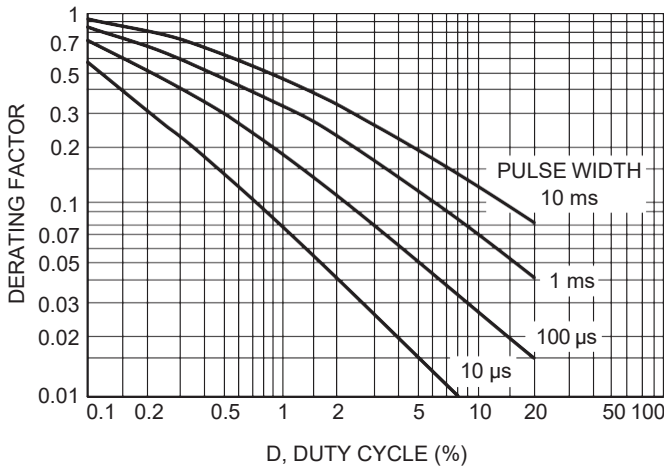

Figure 5. Typical Derating Factor for Duty Cycle

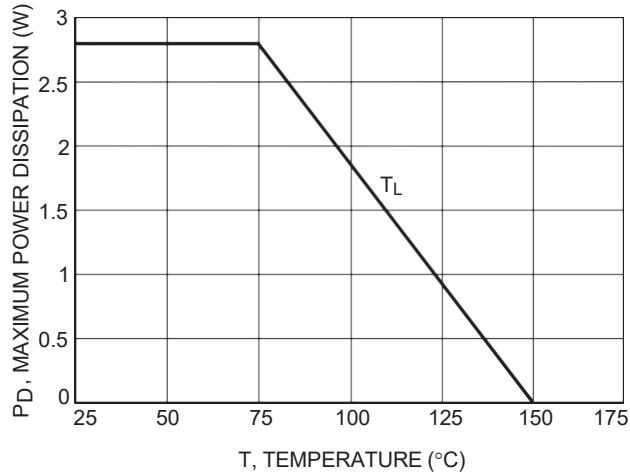

Figure 6. Steady State Power Derating

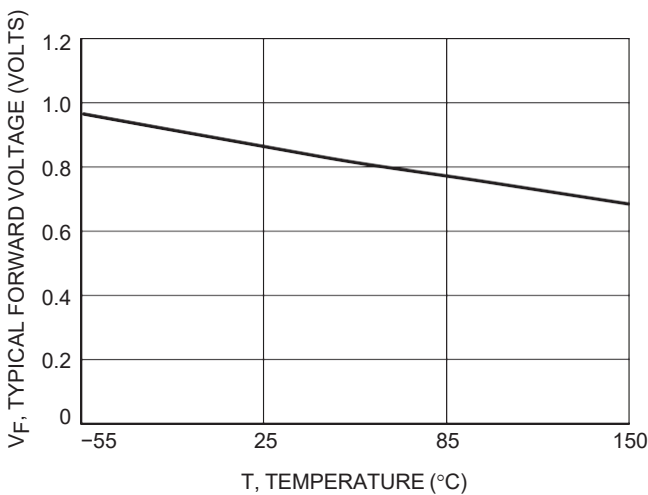

Figure 7. Forward Voltage

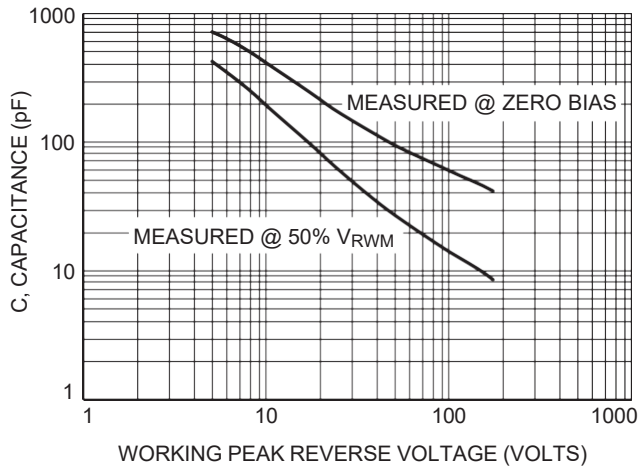
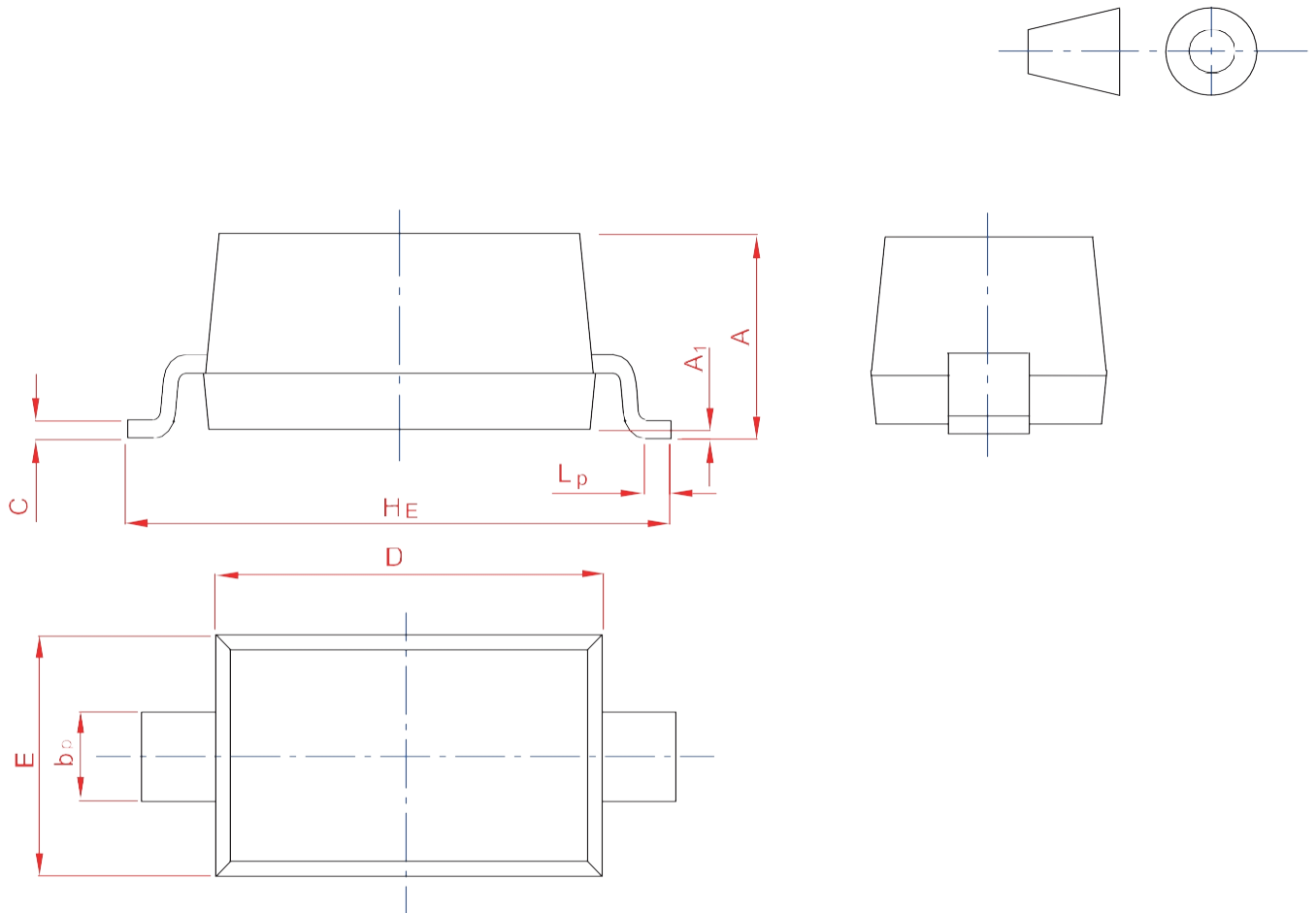

Figure 8. Capacitance versus Working Peak Reverse Voltage

PACKAGE OUTLINE

Plastic surface mounted package; 2 leads

SOD-123



UNIT	A	bp	C	D	E	HE	A1	Lp
mm	1.20	0.60	0.135	2.75	1.65	3.85	0.10	0.50
	0.90	0.50	0.100	2.55	1.55	3.55	0.01	0.20