

ESDSOT04C-ESDSOT36C

Dual Transient Voltage Suppressors for ESD Protection

Features

- SOT-23 Package
- 2 Unidirectional Transil functions
- Peak Power Dissipation 300W @8 x 20 us Pulse
- Low Leakage
- Fast Response Time < 1 ns
- Protects I/O Port
- ESD Protection to IEC 61000-4-2 Level 4, 15KV(Air), 8KV(Contact)
- 16KV Human Body Model ESD Requirements
- RoHS Compliant in Lead-Free Versions

Applications

- Computers
- Printers
- Communication Systems

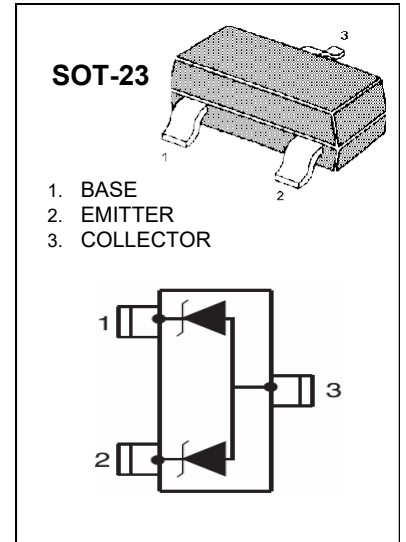

Absolute Maximum Ratings

Symbol	Parameter	Value	Units
P_{PP}	Peak Pulse Power ($t_p = 8/20\mu s$)	300	W
T_L	Maximum lead temperature for soldering during 10s	260	°C
T_{stg}	Storage Temperature Range	-55 to +15	°C
T_{op}	Operating Temperature Range	-40 to +125	°C
T_j	Maximum junction temperature	150	°C
V_{PP}	Electrostatic discharge		
	MIL STD 883C -Method 3015-6	25	kv
	IEC61000-4-2 air discharge	16	
IEC61000-4-2 contact discharge	9		

Electrical Characteristics

Symbol	Parameter
V_{RM}	Stand-off voltage
V_{BR}	Breakdown voltage
V_{CL}	Clamping voltage
I_{RM}	Leakage current
I_{PP}	Peak pulse current
αT	Voltage temperature coefficient
V_F	Forward voltage drop
C	Capacitance
R_d	Dynamic resistance

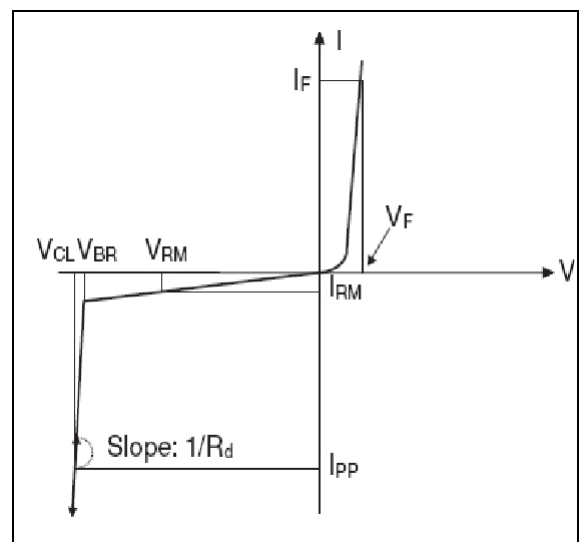

Electrical Characteristics Ratings at 25°C ambient temperature unless otherwise specified.

Part Numbers	Marking	Rated Stand-off Voltage	Maximum Leakage Current	Minimum Breakdown Voltage	Maximum Clamping Voltage		Maximum Pulse Peak Current	Maximum Capacitance
			@ V_{RM}	1mA	1A ¹⁾	5A ¹⁾	$t_p=8/20\mu s$	0v, 1MHz
		V_{RM}	I_{RM}	V_{BR}	V_{CL}		I_{PPM}	C
		V	μA	V	V	V	A	pF
ESDSOT04C	04C	4.0	3.0	5.0	8.5	10.5	17	300
ESDSOT05C	05C	5.0	1.0	6.0	9.8	12.5	17	220
ESDSOT08C	08C	8.0	1.0	8.5	13.4	15.0	15	190
ESDSOT12C	12C	12.0	1.0	13.3	19.0	28.0	12	150
ESDSOT15C	15C	15.0	1.0	16.7	24.0	35.0	10	140
ESDSOT24C	24C	24.0	1.0	26.7	43.0	60.0	5	83
ESDSOT36C	36C	36.0	1.0	40	60.0	75.0	2	80

1).8/20 waveform used. (see fig2.)

Typical Characteristics

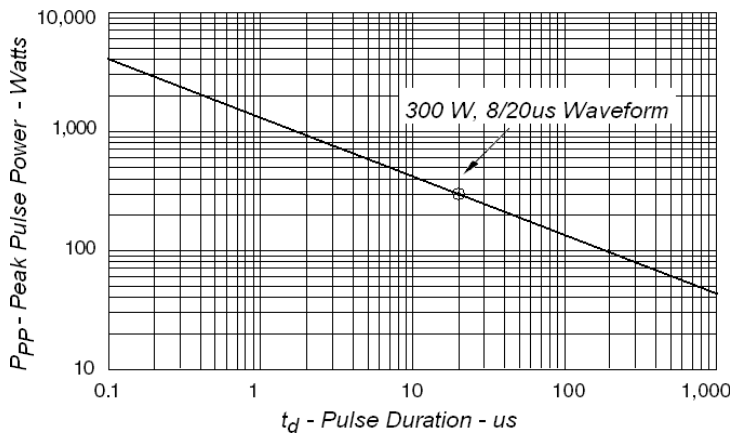

Fig1. Peak Pulse Power VS Pulse Time

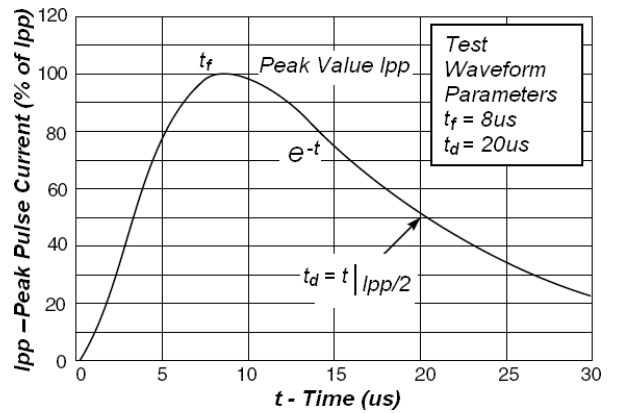

Fig2. Pulse Waveform

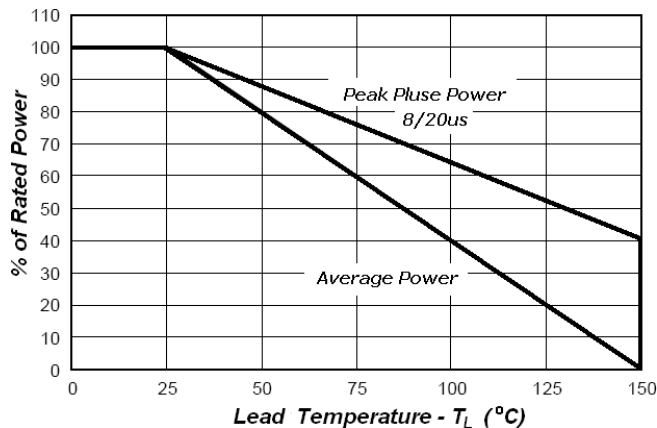
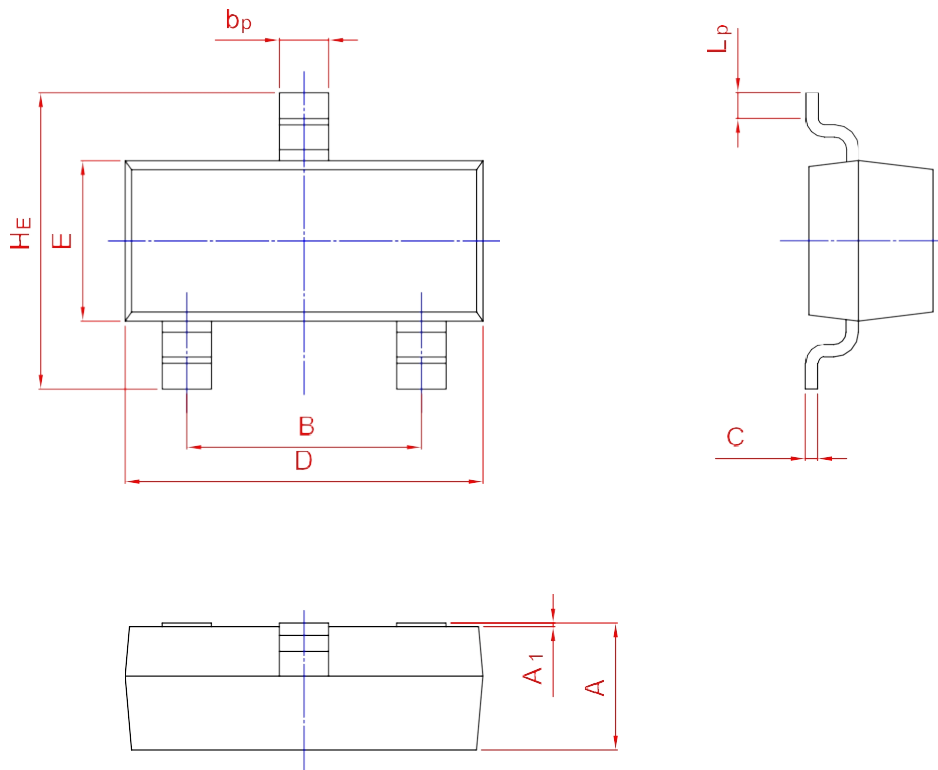
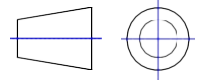

Fig3. Power Derating

PACKAGE OUTLINE

Plastic surface mounted package; 3 leads

SOT-23



UNIT	A	B	b _p	C	D	E	H _E	A ₁	L _p
mm	1.40	2.04	0.50	0.19	3.10	1.65	3.00	0.100	0.50
	0.95	1.78	0.35	0.08	2.70	1.20	2.20	0.013	0.20